



 **BMX & Lifestyle Bikes 2017**

RADIO

WETHEPEOPLE

BOMBTRACK
BICYCLE COMPANY



RADIO



INTRO



RADIO COMPLETE BIKE 2017 PREVIEW

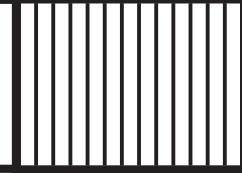

WELCOME TO THE RADIO BIKES 2017 COMPLETE BIKE PREVIEW

NOW APPROACHING OUR SEVENTH YEAR AS A COMPLETE BIKE BRAND, THE RADIO BIKES 2017 RANGE REALLY IS A TESTAMENT TO JUST HOW GREAT A COMPLETE BIKE CAN BE WITHOUT HAVING TO BREAK THE BANK. THE PAST YEAR HAS BEEN A HUGE ONE FOR RADIO, WITH FRESH FACES ON THE TEAM, PLENTY OF TRIPS AND INCREDIBLE RIDING VIDEOS FROM AROUND THE GLOBE; RADIO'S WORLDWIDE PRESENCE HAS NEVER BEEN STRONGER.

OUR 2017 COLLECTION BEGINS ONCE AGAIN WITH THE DICE, THE PERFECT BEGINNERS BIKE. THE DICE COMES IN A 16", 18" AND FULL 20" VERSION, AND NOW THE NEW 20" FS VERSION THAT INCLUDES A GYRO AND FRONT BRAKE, GIVING YOU THE RIGHT START IN THE SPORT OF BMX. CATERING TO THE EXPANDING 18" MARKET, YOU WILL NOW FIND AN 18" VERSION OF THE SAIKO, WHICH BRINGS 25-9 GEARING AND UPGRADED COMPONENTS TO A YOUNGER RIDER.

WE BELIEVE THERE IS A BIKE FOR EVERYONE IN THE 2017 LINE, AND AS THE RANGE CONTINUES YOU WILL FIND BRIGHT AND VIBRANT COLOR SCHEMES, CONTRASTED BY STEALTHY MATT BLACKS WITH SUBTLE COLOR DETAILING. THE DARKO RETURNS IN A WILD MATT NEON GREEN OPTION WITH WHITE TREAD TIRES, WHILST THE VALAC IS BACKED UP WITH YET ANOTHER SE-

LECTION OF INTRICATE COLOR SCHEMES SIMILAR TO WHAT OUR TEAM RIDERS ARE RUNNING. THE ASTRON IS NOW A FULLY-BREAD PARK SETUP, WITH GEOMETRY INPUT FROM THE TEAM, A SALT AM ROTOR SYSTEM AND TWO MESMERIZING COLORS, RED SPLATTER OR BLUE CHROME. OUR FLAGSHIP BIKE THE COMRAD, IS NOW A FULLY STREET FOCUSED MACHINE AND COMES WITH A SALTPLUS FREECOASTER HUB AND AFTERMARKET RADIO AND ÉCLAT PARTS. OUR 26" DIRT JUMP BIKES GET A FULL REVAMP FOR 2017. WITH ALL NEW GEOMETRY, COMPONENTRY FROM AVID AND ROCKSHOX, AND EVEN A FULL COMPETITION SPEC ALLOY FRAME ON THE GRIFFIN PRO.

PLEASE TAKE YOUR TIME AS YOU GO THROUGH THE RADIO 2017 LINE, WE COULDN'T BE MORE PROUD OF HOW FAR OUR BIKES HAVE COME OVER THE PAST 7 YEARS, AND WE THINK YOU WILL HAVE TO AGREE WHEN WE SAY THIS IS OUR MOST PROGRESSIVE RANGE OF BIKES TO DATE.

PLEASE NOTE: THE BIKES FEATURED IN THIS PREVIEW PDF ARE RENDERING CONCEPT IMAGES ONLY. FINAL COLOURS, FINISHES AND COMPONENT SPECS MAY BE SUBJECT TO CHANGE AND PRODUCTION BIKES MAY APPEAR DIFFERENT.



RADIO

RADIO

DICE 16"

RADIO COMPLETE BIKE 2017 PREVIEW

Sfr .379.00



16"



 METALLIC CYAN

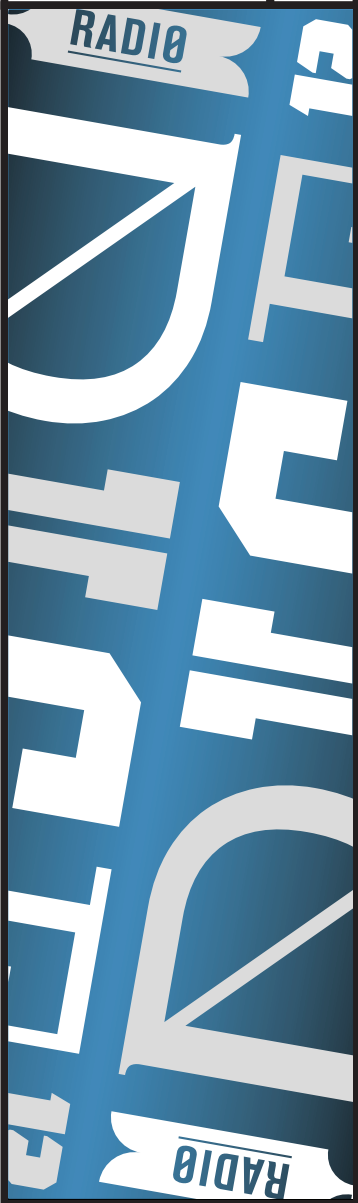

RADIO



DICE 16"

RADIO COMPLETE BIKE 2017 PREVIEW



16"



METALLIC CYAN

SPECS



METALLIC CYAN **W1799A**

FRAME GEOMETRY

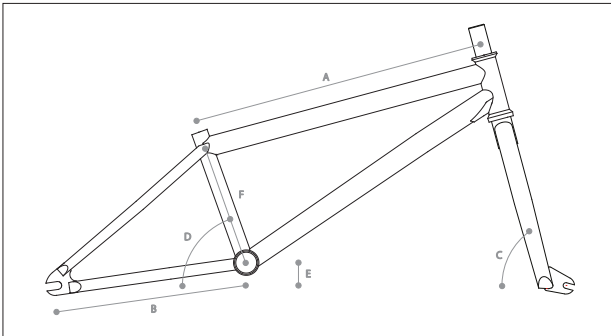

A	TOP TUBE LENGHT	15.75"
B	CHAIN STAY LENGTH	10.8"
C	HEAD TUBE ANGLE	75 °
D	SEAT TUBE ANGLE	71.5 °
E	BOTTOM BRACKET HEIGHT	9.75"
F	STANDOVER HEIGHT	6.6"

BAR GEOMETRY

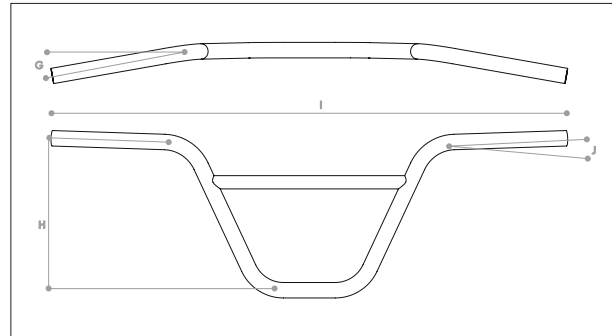

G	BACKSWEEP	10 °
H	RISE	6.8"
I	WIDTH	23.6"
J	UPSWEEP	3 °

FRAME	full 1020 hi-ten
FORK	RADIO "Rookie" 1020 hi-ten fork, crmo steerer
BARS	1020 hi-ten
GRIPS	RADIO "Junior" grip
STEM	SALT "Junior V2" top loading stem, 40 mm reach
HEADSET	FSA "a-head-set" loose ball
GYRO	-
LEVER	RADIO "Junior" alloy brake levers
BRAKES	RADIO "AM" alloy caliper brake front / RADIO "AM" alloy u-brake rear
CRANKS	RADIO "Rookie" tubular 3pc crank crmo 140 mm, 8 spline
BB	USA size, loose ball
PEDALS	SALT "Slim" nylon / fiberglass pedals
CHAIN	SALT "AM" chain, 510h type
SPROCKET	RADIO "AM" steel 28t sprocket
DRIVER	SALTPLUS "PRO" 13t freewheel
FRONT HUB	RADIO "Rookie" steel hub, 1b, 3/8"s, 28h
REAR HUB	RADIO "Rookie" steel hub, 1b, 13T, 3/8" axle, 28h
FRONT RIM	SALT "AM" rim, straight single wall, 28h
REAR RIM	SALT "AM" rim, straight single wall, 28h
SEAT	RADIO "Century16" combo seat
SEAT POST	-
SEAT CLAMP	RADIO "Slim" alloy seatclamp
TIRES	SALT "Strike" tires 2.2" front & rear
PEGS	RADIO "AM" 32 mm x 85 mm steel pegs (1 pair)
WEIGHT	9.6 kg (21.27 lbs) w/o pegs & front brake

RADIO

DICE 18"

RADIO COMPLETE BIKE 2017 PREVIEW

Sfr . 399 . 00



18"



■ MATT BLACK



RADIO



DICE 18"

RADIO COMPLETE BIKE 2017 PREVIEW



18"



MATT BLACK, METALLIC CYAN

SPECS



MATT BLACK

W1799B

METALLIC CYAN

W1799C

FRAME GEOMETRY

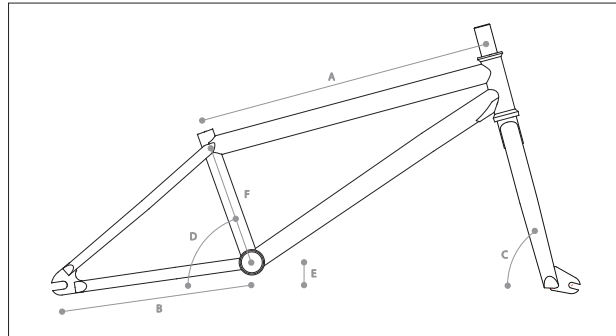

BAR GEOMETRY

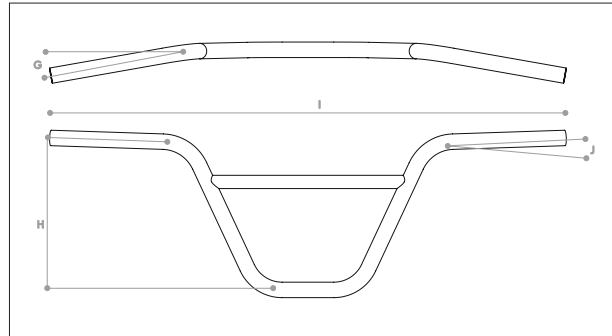

A	TOP TUBE LENGTH	17.55"
B	CHAIN STAY LENGTH	12.55"
C	HEAD TUBE ANGLE	75 °
D	SEAT TUBE ANGLE	71.5 °
E	BOTTOM BRACKET HEIGHT	10.75"
F	STANDOVER HEIGHT	7.3"

G	BACKSWEEP	10 °
H	RISE	7.9"
I	WIDTH	26.5"
J	UPSWEEP	3 °

FRAME	full 1020 hi-ten
FORK	RADIO "AM 18"" 1020 hi-ten fork, crmo steerer
BARS	1020 hi-ten
GRIPS	RADIO "AM" grips
STEM	SALT "Junior V2" top loading stem, 40 mm reach
HEADSET	FSA "a-head-set" loose ball
GYRO	-
LEVER	RADIO "AM" alloy rear brake lever
BRAKES	"AM" alloy rear u-brake
CRANKS	RADIO "Rookie" tubular 3pc crank crmo 152 mm, 8 spline
BB	USA size, loose ball
PEDALS	SALT "Slim" nylon / fibreglass pedals
CHAIN	SALT "AM" chain, 510h type
SPROCKET	RADIO "AM" steel 30t sprocket
DRIVER	SALTPLUS "PRO" 13t freewheel
FRONT HUB	RADIO "Rookie" steel hub, 1b 3/8"s, 28h
REAR HUB	RADIO "Rookie" steel hub, 1b, 13T, 3/8"s axle, 28h
FRONT RIM	SALT "AM" rim, straight single wall, 28h
REAR RIM	SALT "AM" rim, straight single wall, 28h
SEAT	RADIO "Century18" combo seat
SEAT POST	-
SEAT CLAMP	RADIO "Slim" alloy seatclamp
TIRES	SALT "Strike" tires 2.2" front & rear
PEGS	RADIO "AM" 35 mm x 89 mm steel pegs (1 pair)
WEIGHT	10.71 kg (23.61 lbs) w/o pegs & front brake

RADIO

DICE FS 20"

RADIO COMPLETE BIKE 2017 PREVIEW

Sfr .429.00



20" X

METALLIC CYAN



RADIO

DICE FS 20"

RADIO COMPLETE BIKE 2017 PREVIEW

SPECS



20"



MATT BLACK, METALLIC CYAN

RotorBrake System



RotorBrake System



MATT BLACK

W1799D

METALLIC CYAN

W1799E

FRAME GEOMETRY

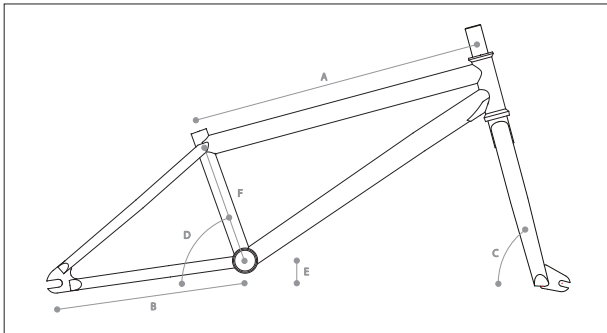

BAR GEOMETRY

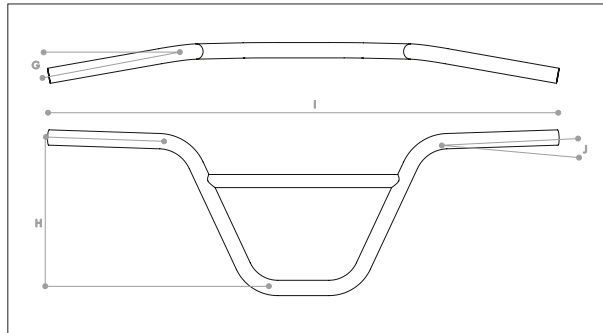

A	TOP TUBE LENGTH	20"
B	CHAIN STAY LENGTH	13"
C	HEAD TUBE ANGLE	75 °
D	SEAT TUBE ANGLE	71.5 °
E	BOTTOM BRACKET HEIGHT	11.75"
F	STANDOVER HEIGHT	7.9"

G	BACKSWEEP	11 °
H	RISE	8.6"
I	WIDTH	28.75"
J	UPSWEEP	2 °

FRAME	full 1020 hi-ten
FORK	RADIO "AM 20" 1020 hi-ten fork, crmo steerer
BARS	1020 hi-ten
GRIPS	RADIO "AM" grips
STEM	SALT "AM" top loading stem, 50 mm reach
HEADSET	FSA "a-head-set" loose ball
GYRO	DICE FS comes with SALT "AM" rotor with SALT "AM" rotor cables
LEVER	RADIO "AM" alloy rear brake lever
BRAKES	RADIO "AM" alloy rear u-brake
CRANKS	RADIO "Rookie" tubular 3pc crank crmo 165 mm, 8 spline
BB	USA size, loose ball
PEDALS	SALT "Slim" nylon / fibreglass pedals
CHAIN	SALT "AM" chain, 510h type
SPROCKET	RADIO "AM" steel 30t sprocket
DRIVER	SALTPLUS "PRO" 13t freewheel
FRONT HUB	RADIO "Rookie" steel hub, 1b 3/8"s, 36h
REAR HUB	RADIO "Rookie" steel hub, 1b, 13T, 14 mm axle, 36h
FRONT RIM	SALT "AM" rim, straight single wall, 36h
REAR RIM	SALT "AM" rim, straight single wall, 36h
SEAT	RADIO "Century" mid padded combo seat
SEAT POST	-
SEAT CLAMP	RADIO "Slim" alloy seatclamp
TIRES	SALT "Strike" tires 2.35" front & 2.2" rear
PEGS	RADIO "AM" 35 mm x 89 mm steel pegs (1 pair)
WEIGHT	11.69 kg (25.77 lbs) w/o pegs & front brake

RADIO



EVOL

RADIO COMPLETE BIKE 2017 PREVIEW



20"



NEON GREEN

Sfr. 449.00



RADIO



EVOL

RADIO COMPLETE BIKE 2017 PREVIEW



20"



■ NEON GREEN

SPECS



NEON GREEN

W1799F

FRAME GEOMETRY

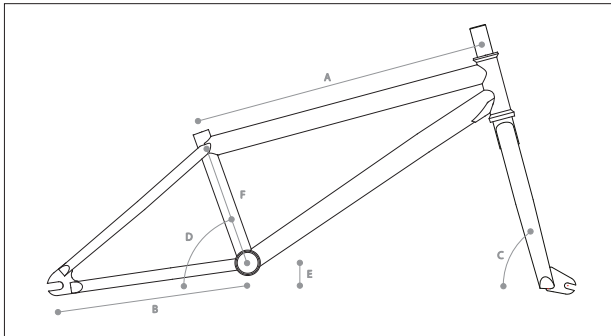

BAR GEOMETRY

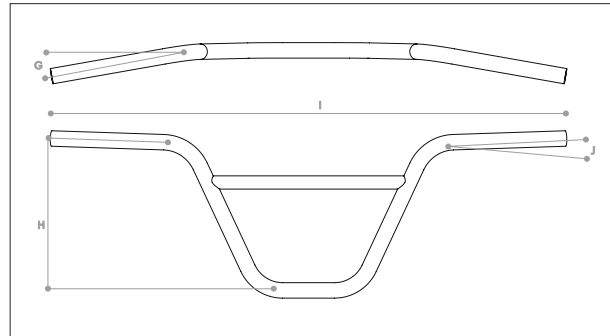

A	TOP TUBE LENGTH	20.3"
B	CHAIN STAY LENGTH	13.2"
C	HEAD TUBE ANGLE	75 °
D	SEAT TUBE ANGLE	71.5 °
E	BOTTOM BRACKET HEIGHT	11.75"
F	STANDOVER HEIGHT	8.3"

G	BACKSWEEP	11 °
H	RISE	8.6"
I	WIDTH	28.75"
J	UPSWEEP	2 °

FRAME	full 1020 hi-ten
FORK	RADIO "AM 20" 1020 hi-ten fork, crmo steerer
BARS	1020 hi-ten
GRIPS	SALT "EX" grips
STEM	SALT "AM" top loading stem, 50 mm reach
HEADSET	FSA "a-head-set" loose ball
GYRO	holes for removable gyro tabs
LEVER	RADIO "AM" alloy rear brake levers
BRAKES	SALTPLUS "Moto XL" rear alloy u-brake
CRANKS	RADIO "Rookie" tubular 3pc crank crmo 165 mm, 8 spline
BB	mid size, press fit, sealed bearing
PEDALS	SALT "AM" nylon / fibreglass pedals
CHAIN	SALT "AM" chain, 510h type
SPROCKET	RADIO "AM" steel 25t sprocket
DRIVER	9T cassette driver, lb
FRONT HUB	RADIO "Rookie" steel hub, lb 3/8"s, 36h
REAR HUB	RADIO "AM" cassette hub, semi-sealed, 9t, 14 mm axle, 36h
FRONT RIM	SALT "Valon" rim, straight single wall, 36h
REAR RIM	SALT "Valon" rim, straight single wall, 36h
SEAT	RADIO "Century" mid padded combo seat
SEAT POST	-
SEAT CLAMP	RADIO "Slim" alloy seatclamp
TIRES	SALT "Tracer" tires 2.35" front & rear
PEGS	RADIO "AM" 35 mm x 89 mm steel pegs (1 pair)
WEIGHT	tbc

RADIO

SAIKO 20"

RADIO COMPLETE BIKE 2017 PREVIEW

Sfr. 469.00



20"



■ MATT BLACK



RADIO



SAIKO 20"

RADIO COMPLETE BIKE 2017 PREVIEW



20"



MATT BLACK

SPECS



MATT BLACK

W1799G

FRAME GEOMETRY

BAR GEOMETRY

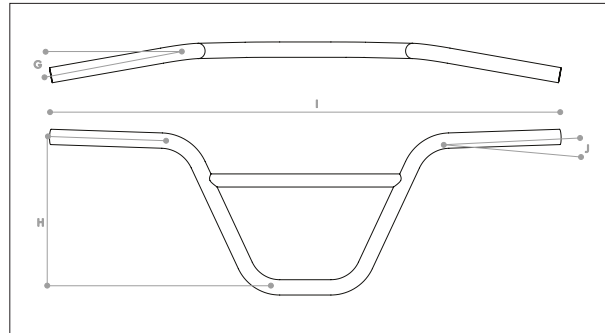
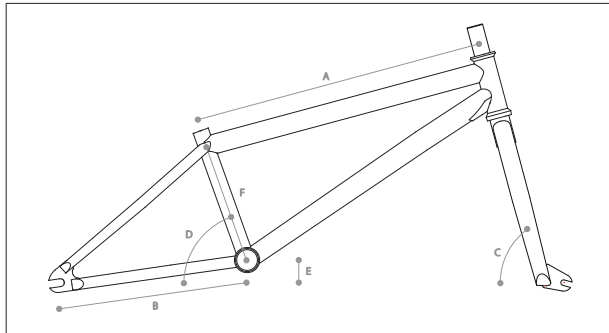

A	TOP TUBE LENGTH	20.6"
B	CHAIN STAY LENGTH	13.2"
C	HEAD TUBE ANGLE	75 °
D	SEAT TUBE ANGLE	71.5 °
E	BOTTOM BRACKET HEIGHT	11.75"
F	STANDOVER HEIGHT	8.6"

G	BACKSWEEP	11 °
H	RISE	8.6"
I	WIDTH	28.75"
J	UPSWEEP	2 °

FRAME	crmo down tube, 1020 hi-ten
FORK	RADIO "AM 20" 1020 hi-ten fork, crmo steerer
BARS	1020 hi-ten
GRIPS	SALT "EX" grips
STEM	SALT "AM" top loading stem, 50 mm reach
HEADSET	SALT "PRO" int. headset, sealed bearing
GYRO	holes for removable gyro tabs
LEVER	RADIO "AM" alloy rear brake levers
BRAKES	SALTPLUS "Moto XL" rear alloy u-brake
CRANKS	RADIO "Rookie" tubular 3pc crank crmo 170 mm, 8 spline
BB	mid size, press fit, sealed bearing
PEDALS	SALT "AM" nylon / fiberglass pedals
CHAIN	SALT "AM" chain, 510h type
SPROCKET	RADIO "AM" steel 25t sprocket
DRIVER	9T cassette driver, lb
FRONT HUB	RADIO "Rookie" steel hub, lb 3/8"s, 36h
REAR HUB	RADIO "AM" cassette hub, semi-sealed, 9t, 14 mm axle, 36h
FRONT RIM	SALT "Valon" rim, straight single wall, 36h
REAR RIM	SALT "Valon" rim, straight single wall, 36h
SEAT	RADIO "Century" mid padded combo seat
SEAT POST	-
SEAT CLAMP	RADIO "Slim" alloy seatclamp
TIRES	SALT "Tracer" tires 2.35" front & rear
PEGS	RADIO "AM" 35 mm x 89 mm steel pegs (1 pair)
WEIGHT	tbc

RADIO

DARKO

RADIO COMPLETE BIKE 2017 PREVIEW

Sfr. 499.00



20"



MATT NEON GREEN



RADIO

DARKO

RADIO COMPLETE BIKE 2017 PREVIEW

SPECS



20"



MATT BLACK,
MATT NEON GREEN



MATT BLACK

W1799H

MATT NEON GREEN

W1799I

FRAME GEOMETRY

BAR GEOMETRY

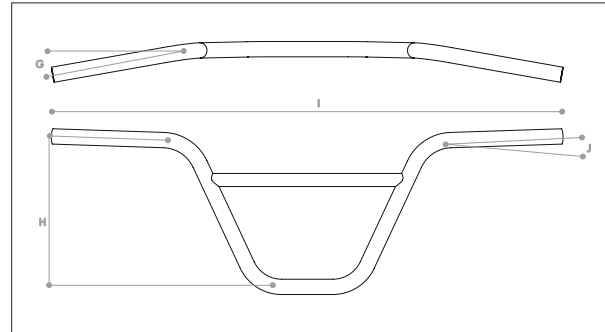
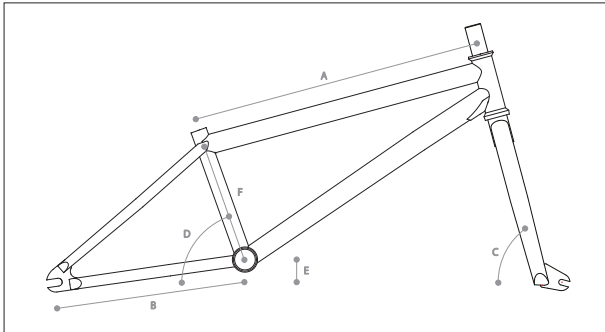

A	TOP TUBE LENGHT	20.5" & 21"
B	CHAIN STAY LENGTH	13.2"
C	HEAD TUBE ANGLE	75 °
D	SEAT TUBE ANGLE	71 °
E	BOTTOM BRACKET HEIGHT	11.7"
F	STANDOVER HEIGHT	8.6" / 8.9"

G	BACKSWEEP	11 °
H	RISE	8.75"
I	WIDTH	29.5"
J	UPSWEEP	2 °

FRAME	toptube & downtube crmo, 1020 hi-ten, removable pivots & guides
FORK	RADIO "AM" 1020 hi-ten fork, crmo steerer
BARS	1020 hi-ten
GRIPS	RADIO "Frequency" grips, flangless
STEM	SALT "PRO" top loading stem, 50 mm reach
HEADSET	SALT "PRO" int. headset, sealed bearing
GYRO	holes for removable gyro tabs
LEVER	SALT "Moto" alloy rear brake lever
BRAKES	SALTPLUS "Moto XL" rear alloy u-brake
CRANKS	RADIO "AM" tubular 3pc crank crmo 170 mm, 8 spline
BB	mid size, press fit, sealed bearing
PEDALS	SALTPLUS "Stealth" nylon / fibreglass pedals
CHAIN	SALT "AM" chain, 510h type
SPROCKET	RADIO "AM" steel 25t sprocket
DRIVER	9T cassette driver, lb
FRONT HUB	RADIO "AM" alloy hub, lb, 3/8"s, 36h
REAR HUB	RADIO "AM" cassette hub, semi-sealed, 9t, 14 mm axle, 36h
FRONT RIM	SALT "Valon" rim, straight single wall, 36h
REAR RIM	SALTPLUS "Summit" rim, straight double wall, 36h
SEAT	RADIO "Century" fat padded combo seat
SEAT POST	-
SEAT CLAMP	integrated slim seat clamp
TIRES	SALT "Tracer" tires 2.35" front & rear
PEGS	RADIO "AM" 35 mm x 89 mm steel pegs (1 pair)
WEIGHT	tbc

RADIO

VALAC

RADIO COMPLETE BIKE 2017 PREVIEW

Sfr. 539.00



20"



GLOSSY GOLD

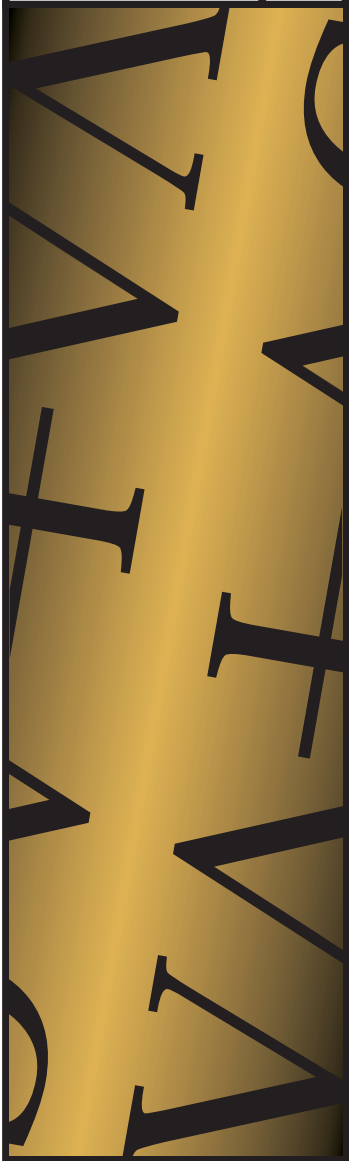

RADIO



VALAC

RADIO COMPLETE BIKE 2017 PREVIEW



20"



GLOSSY GOLD

SPECS



GLOSSY GOLD

W1799J

FRAME GEOMETRY

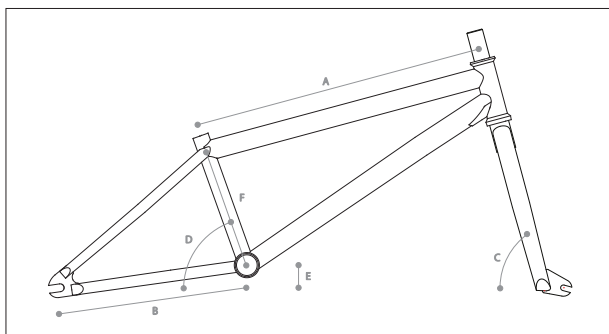

BAR GEOMETRY

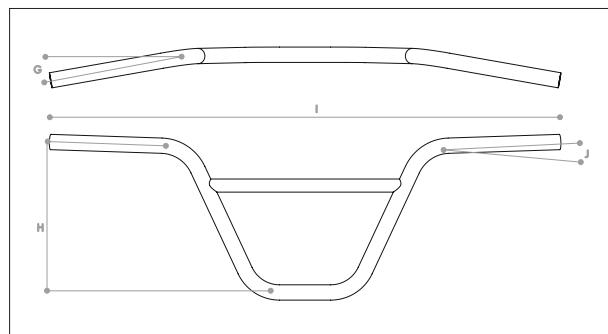

A	TOP TUBE LENGTH	20.75"
B	CHAIN STAY LENGTH	13.2"
C	HEAD TUBE ANGLE	75.5 °
D	SEAT TUBE ANGLE	71 °
E	BOTTOM BRACKET HEIGHT	11.8"
F	STANDOVER HEIGHT	8.75"

G	BACKSWEEP	12 °
H	RISE	9"
I	WIDTH	29.5"
J	UPSWEEP	2 °

FRAME	toptube, downtube & chainstays crmo, 1020 hi-ten, removable pivots & guides
FORK	RADIO "PRO" full crmo fork, crmo steerer
BARS	1020 hi-ten
GRIPS	RADIO "Frequency" grips, flangless
STEM	SALT "Comp" top loading stem, 50 mm reach
HEADSET	SALT "PRO" int. headset, sealed bearing
GYRO	holes for removable gyro tabs
LEVER	SALT "Moto" alloy rear brake lever
BRAKES	SALTPLUS "Moto XL" rear alloy u-brake
CRANKS	RADIO "AM" tubular 3pc crank crmo 170 mm, 8 spline
BB	mid size, press fit, sealed bearing
PEDALS	SALTPLUS "Stealth" nylon / fibreglass pedals
CHAIN	SALT "AM" chain, 510h type
SPROCKET	RADIO "PRO" 6061 T6 alloy 25t sprocket
DRIVER	9t 1-piece cassette driver, sealed bearing
FRONT HUB	RADIO "AM" alloy hub, sb, 3/8" axle, 36h
REAR HUB	RADIO "PRO" alloy cassette hub, sb, 9t, 14 mm hollow axle, 36h
FRONT RIM	SALT "Valon" rim, straight single wall, 36h
REAR RIM	SALTPLUS "Summit" rim, straight double wall, 36h
SEAT	RADIO "Century" fat padded tripod seat
SEAT POST	Radio "Tripod" seatpost, alloy
SEAT CLAMP	integrated slim seat clamp
TIRES	SALT "Tracer" tires 2.35" front & rear
PEGS	RADIO "AM" 35 mm x 89 mm steel pegs (1 pair)
WEIGHT	tbc

RADIO

ASTRON

RADIO COMPLETE BIKE 2017 PREVIEW



20"



■ BLUE CHROME

Sfr. 579.00

Rotor Sfr. 649.00

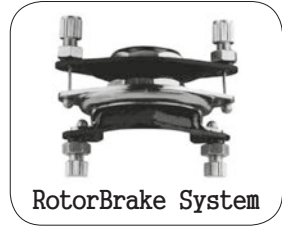

Rotor Brake System

RADIO



ASTRON

RADIO COMPLETE BIKE 2017 PREVIEW



20"



BLUE CHROME

SPECS



CHROME

W1699J



RotorBrake System

BLUE CHROME

W1799K

FRAME GEOMETRY

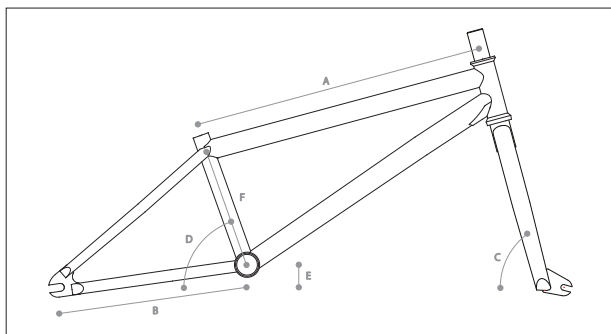

BAR GEOMETRY

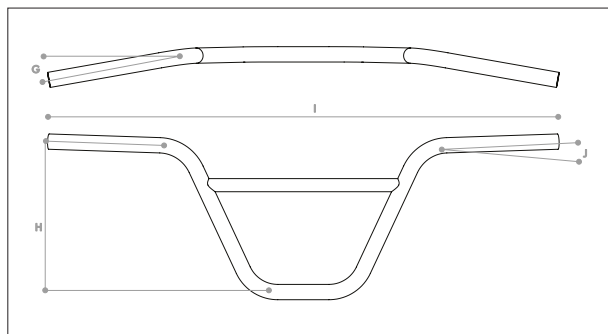

A	TOP TUBE LENGTH	20.6"
B	CHAIN STAY LENGTH	13.2"
C	HEAD TUBE ANGLE	75.5 °
D	SEAT TUBE ANGLE	71 °
E	BOTTOM BRACKET HEIGHT	11.6"
F	STANDOVER HEIGHT	7.9"

G	BACKSWEEP	11 °
H	RISE	8.75"
I	WIDTH	29.5"
J	UPSWEEP	2 °

FRAME	toptube, downtube & chainstays crmo, 1020 hi-ten, removable pivots & guides
FORK	RADIO "PRO" full crmo fork, crmo steerer
BARS	full 4130 crmo bar
GRIPS	RADIO "Frequency" grips
STEM	SALT "Comp" top loading stem, 50 mm reach
HEADSET	SALT "PRO" int. headset, sealed bearing
GYRO	SALT "AM" rotor with alloy cnc rotor plate & SALT "AM" rotor cables
LEVER	SALT "Moto" alloy rear brake lever
BRAKES	SALTPLUS "Moto XL" rear alloy u-brake
CRANKS	RADIO "AM" tubular 3pc crank crmo 170 mm, 8 spline
BB	mid size, press fit, sealed bearing
PEDALS	SALTPLUS "Forum" slim nylon / fibreglass pedals
CHAIN	SALT "AM" chain, 510h type
SPROCKET	RADIO "PRO" 6061 T6 alloy 25t sprocket
DRIVER	9t 1-piece cassette driver, sealed bearing
FRONT HUB	RADIO "PRO" alloy hub, sb, 3/8"s female axle, 36h
REAR HUB	RADIO "PRO" alloy cassette hub, sb, 9t, 14 mm hollow axle, 36h
FRONT RIM	SALTPLUS "Summit" rim, aero double wall, 36h
REAR RIM	SALTPLUS "Summit" rim, straight double wall, 36h
SEAT	RADIO "Century" slim padded combo seat
SEAT POST	-
SEAT CLAMP	integrated slim seat clamp
TIRES	SALTPLUS "PITCH FLOW" tires 2.25" front & rear
PEGS	RADIO "AM" 35 mm x 89 mm steel pegs (1 pair)
WEIGHT	tbc

RADIO

COMRAD

RADIO COMPLETE BIKE 2017 PREVIEW

Sfr. 749.00



20"



ED COPPER



RADIO



COMRAD

RADIO COMPLETE BIKE 2017 PREVIEW



20"



ED COPPER

SPECS



ED COPPER

W1799L

FRAME GEOMETRY

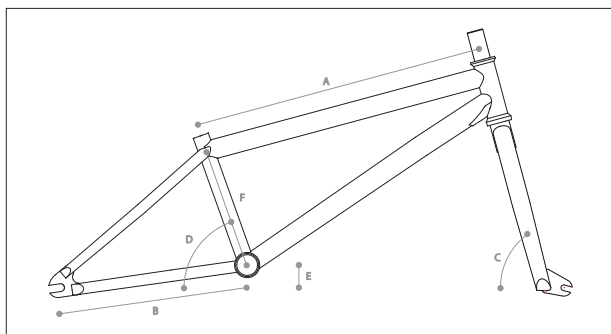

A	TOP TUBE LENGTH	21"
B	CHAIN STAY LENGTH	13.6"
C	HEAD TUBE ANGLE	75.5 °
D	SEAT TUBE ANGLE	71 °
E	BOTTOM BRACKET HEIGHT	11.75"
F	STANDOVER HEIGHT	8.85"

BAR GEOMETRY

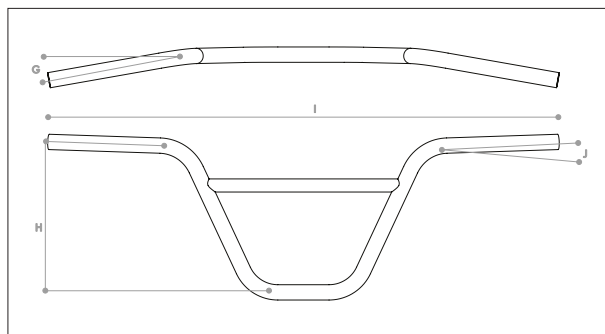

G	BACKSWEEP	12 °
H	RISE	9"
I	WIDTH	29.5"
J	UPSWEEP	2 °

FRAME	4130 full crmo frame, removable pivots & guides, heat treated dropouts
FORK	RADIO "PRO" full crmo fork, crmo steerer
BARS	full 4130 crmo bar
GRIPS	SALTPLUS "XL" grips, flangless
STEM	RADIO "Axis" 6061 T6 alloy cnc top loading stem, 50 mm reach
HEADSET	SALTPLUS "Echo" int. headset, sealed bearing
GYRO	holes for removable gyro tabs
LEVER	SALTPLUS "Geo" rear alloy brake lever
BRAKES	ÉCLAT "Talon" rear alloy u-brake
CRANKS	RADIO "PRO" tubular 3pc crank crmo 170 mm, 8 spline
BB	mid size, press fit, sealed bearing
PEDALS	SALTPLUS "Stealth" nylon / fibreglass pedals
CHAIN	SALT "AM" chain, 510h type
SPROCKET	RADIO "Axis" 6061 T6 alloy cnc 26t sprocket
DRIVER	9t 1-piece freecoaster driver, sealed bearing, RSD
FRONT HUB	SALT "EX" alloy hub, sb, 3/8" female axle, 36h, SALTPLUS "PRO" nylon guard incl.
REAR HUB	SALTPLUS "PRO" alloy freecoaster hub, sb, 9t, 14 mm axle, 36h, SALTPLUS "PRO" nylon guard incl.
FRONT RIM	SALTPLUS "Summit" rim, straight double wall, 36h
REAR RIM	SALTPLUS "Summit" rim, straight double wall, 36h
SEAT	RADIO "Century" fat padded tripod seat
SEAT POST	Radio "Tripod" seatpost, alloy
SEAT CLAMP	integrated slim seat clamp
TIRES	SALTPLUS "STING" tire 2.40" front / 2.30" rear
PEGS	SALT "Pro" 38 mm x 109 mm steel / nylon sleeve pegs (1 pair)
WEIGHT	tbc

RADIO

FIEND 26"

RADIO COMPLETE BIKE 2017 PREVIEW

Sfr. 699.00



26" X



METALLIC LIME GREEN



RADIO



FIEND 26"

RADIO COMPLETE BIKE 2017 PREVIEW



26"



METALLIC LIME GREEN

SPECS



METALLIC LIME GREEN **W1799M**

FRAME GEOMETRY

BAR GEOMETRY

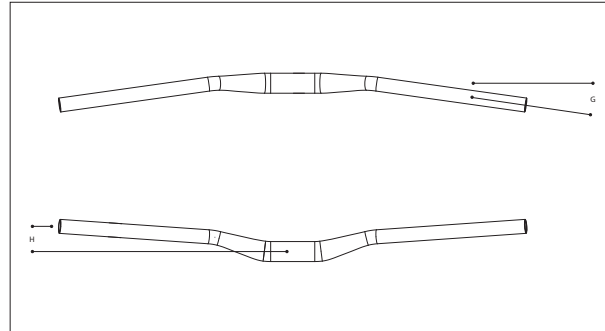
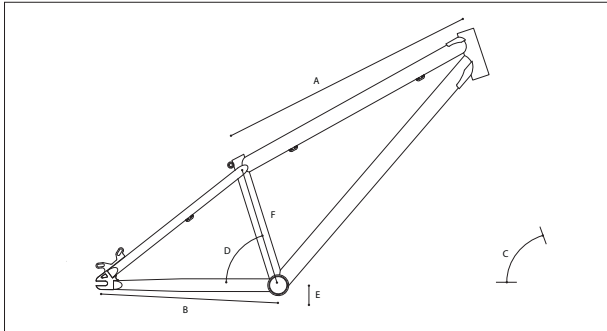

A	TOP TUBE LENGHT	22.6"
B	CHAIN STAY LENGTH	15"
C	HEAD TUBE ANGLE	71.5 °
D	SEAT TUBE ANGLE	72.5 °
E	BOTTOM BRACKET HEIGHT	4 MM DROP
F	STANDOVER HEIGHT	10.7"

G	BACKSWEEP	8 °
H	RISE	40 MM
I	WIDTH	740 MM
J	UPSWEEP	4 °

FRAME	crmo downtube, 1020 hi-ten, intg. seat clamp, double gussett
FORK	RST "Dirt RA", 100 mm travel
BARS	alloy hydro formed
GRIPS	RADIO "Frequency" grips flangless
STEM	RADIO "DJ" front loading stem, alloy cnc, 40 mm reach
HEADSET	SALT "AM" A-headset, loose ball
GYRO	-
LEVER	TEKTRO "RS-360A" front & rear
BRAKES	TEKTRO "836A V-brake" front / "Novela-Disc" 160 mm rear
CRANKS	RADIO "Rookie-Bolt" tubular 3pc crank crmo 170 mm, 8 spline
BB	mid size, press fit, sealed bearing
PEDALS	SALTPLUS "Forum" slim nylon / fibreglass pedals
CHAIN	SALT "AM" chain, 510h type
SPROCKET	RADIO "AM" steel 30t sprocket
DRIVER	14T Lida freewheel
FRONT HUB	RADIO "AM-DJ" alloy hub, loose ball, 3/8"s crmo axle, 32h
REAR HUB	RADIO "AM-DJ", disc hub, sb, 3/8"s crmo axle, 32h
FRONT RIM	SALT "Valon" rim, straight single wall, 32h
REAR RIM	SALTPLUS "Summit" rim, straight double wall, 32h
SEAT	RADIO "Century" slim padded combo seat
SEAT POST	-
SEAT CLAMP	integrated slim seat clamp
TIRES	KENDA "Small Block Eight" tires 2.1" front & rear
PEGS	-
WEIGHT	tbc

12

GRIFFIN

RADIO COMPLETEBIKE 2016 PREVIEW

Sfr. 799.00



26"



GLOSSY METALLIC GREY





GRIFFIN

RADIO COMPLETEBIKE 2016 PREVIEW

SPECS



26"



GLOSSY METALLIC GREY



GLOSSY BLACK

W1699L

FRAME GEOMETRY

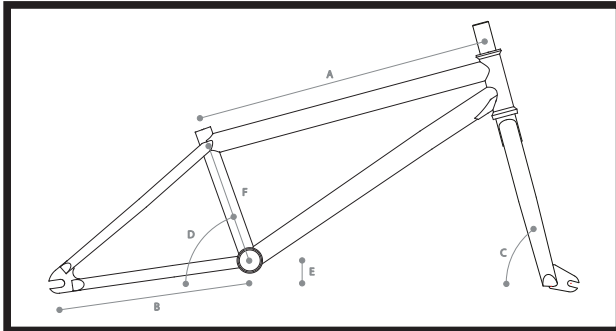

BAR GEOMETRY

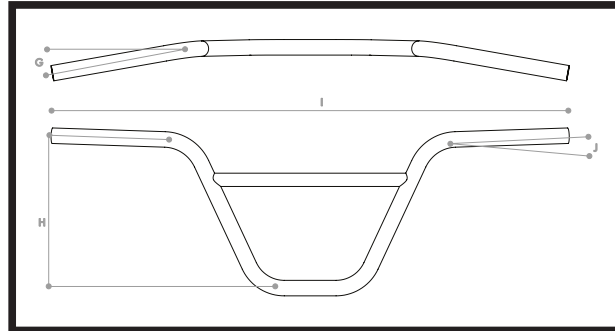

A	TOP TUBE LENGH	22.35"
B	CHAIN STAY LENGTH	15.4"
C	HEAD TUBE ANGLE	70.5°
D	SEAT TUBE ANGLE	72.5°
E	BOTTOM BRACKET HEIGHT	6.5 MM DROP
F	STANDOVER HEIGHT	10.5"

G	BACKSWEEP	8°
H	RISE	38 MM
I	WIDTH	760 MM
J	UPSWEEP	2°

FRAME	crmo top & down tube, intg. seat clamp, double gussett
FORK	RST "Dirt T", 100mm travel
BARS	alloy hydro formed
GRIPS	RADIO "Frequency" grips, flangless
STEM	RADIO "DJ-V2" front loading stem, alloy cnc, 40mm reach
HEADSET	SALT "PRO" int. headset, sealed bearing
GYRO	-
LEVER	AVID "FR 5" front & rear
BRAKES	AVID "BB 5", disc brake, 160mm rotor front & rear
CRANKS	RADIO "Rookie Bolt" tubular 3pc crank crmo 175mm, 8 spline
BB	mid size, press fit, sealed bearing
PEDALS	SALTPLUS "Stealth" nylon/fibreglass pedals
CHAIN	SALT "AM" chain, 510h type
SPROCKET	RADIO "AM" alloy 28t sprocket
DRIVER	13t cog
FRONT HUB	RADIO "Expert-DJ", disc alloy hub, sb, loose ball, 3/8"s crmo axle, 32h
REAR HUB	RADIO "Expert-DJ", disc hub, sb, 3/8"s crmo axle, 32h
FRONT RIM	SALTPLUS "Summit" rim, aero double wall, 32h
REAR RIM	SALTPLUS "Summit" rim, aero double wall, 32h
SEAT	RADIO "TRIPOD" slim padded seat
SEAT POST	alloy "TRIPOD" post
SEAT CLAMP	integrated slim seat clamp
TIRES	KENDA tires "Small Block 8" 2.1" front & rear
PEGS	-
WEIGHT	14.4 kg (31.7 lbs)

RADIO

GRIFFIN PRO
26"

RADIO COMPLETE BIKE 2017 PREVIEW



26"



■ **MATT BLACK**

Sfr. 1299.00



RADIO



GRIFFIN PRO 26"

RADIO COMPLETE BIKE 2017 PREVIEW



26"



■ MATT BLACK

SPECS



MATT BLACK

W17990

FRAME GEOMETRY

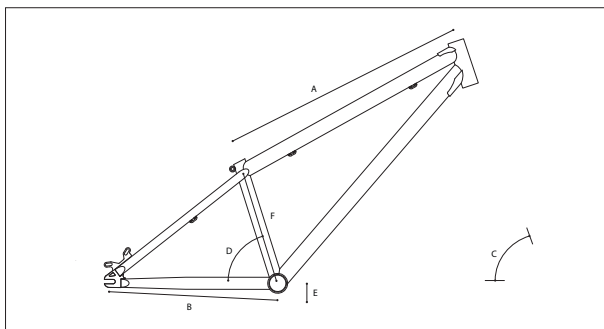

A	TOP TUBE LENGHT	22.8"
B	CHAIN STAY LENGTH	15.5"
C	HEAD TUBE ANGLE	68.5 °
D	SEAT TUBE ANGLE	72.5 °
E	BOTTOM BRACKET HEIGHT	20 MM DROP
F	STANDOVER HEIGHT	10.4"

BAR GEOMETRY

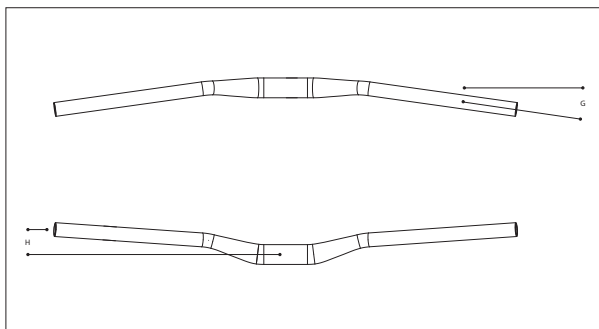

G	BACKSWEEP	8 °
H	RISE	40 MM
I	WIDTH	760 MM
J	UPSWEEP	4 °

FRAME	full 6061 T6 alloy frame, double gussett, forged dropouts & chainstay yoke
FORK	ROCKSHOX "Argyle R", 100 mm travel
BARS	alloy hydro formed
GRIPS	RADIO "Frequency" grips flangless
STEM	RADIO "DJ" front loading stem, alloy cnc, 40 mm reach
HEADSET	FSA "No. 57" 1.5" / 1-1/8" steerer, internal headset
GYRO	-
LEVER	TEKTRO "RS-360A" front, AVID "DB 1" rear
BRAKES	TEKTRO "Novela", disc brake, 160 mm rotor front, AVID "DB 1", hydraulic disc brake, 160 mm rotor rear
CRANKS	RADIO "PRO" forged alloy, 2pc crank, 170 mm
BB	RADIO "PRO" external cup, for 24 mm spindle, sealed bearing
PEDALS	SALTPLUS "Forum" slim nylon / fibreglass pedals
CHAIN	ÉCLAT "Diesel" chain
SPROCKET	SALTPLUS "PRO" 6061 T6 alloy 28t sprocket
DRIVER	11t 1-piece cassette driver, sealed bearing
FRONT HUB	RADIO "PRO-DJ", disc alloy hub, sb, 20 mm thru axle, 32h
REAR HUB	RADIO "PRO-DJ", disc alloy hub, sb, 3/8" s crmo axle, 32h
FRONT RIM	SALTPLUS "Summit" rim, aero double wall, 32h
REAR RIM	SALTPLUS "Summit" rim, aero double wall, 32h
SEAT	RADIO "Century" slim padded pivotal seat
SEAT POST	RADIO "Pivotal" 27.2 mm, alloy pivotal seatpost
SEAT CLAMP	RADIO "Slim" 31.8 mm, alloy seatclamp
TIRES	KENDA "KRANIUM" tires 2.1" front & rear
PEGS	-
WEIGHT	tbc

WETHEPEOPLE 2017 COMPLETE BIKE PREVIEW

AS WE PASS THE 20-YEAR MARK, AND NOW ENTER OUR THIRD DECADE AS A BMX COMPANY OUR PASSION FOR CREATING THE BEST BIKES THINKABLE HAS NEVER BEEN SO STRONG. FEEDING OFF THE ASTOUNDING RESPONSE WE RECEIVED TO THE 2016 COLLECTION AND AN INCREDIBLY SUCCESSFUL AND PRODUCTIVE YEAR WITH THE TEAM. WE HIT THE GROUND RUNNING FOR 2017 AND WE ARE PROUD TO UNVEIL WHAT IS UNDOUBTEDLY OUR FINEST COLLECTION OF COMPLETE BIKES TO DATE.

THE 2017 **WETHEPEOPLE** COLLECTION KICKS OFF WITH SOME EXCITING CHANGES TO THE **ICON** SERIES, WE SEE THE ADDITION OF THE **NOVA**, BRINGING WTP DESIGN AND QUALITY TO A NEW, LOWER PRICE POINT. IN RESPONSE TO THE GROWING PARK SCENE WE NOW OFFER A GYRO EQUIPPED VERSION OF THE 18" AND 20" **CURSE** BIKES, ALLOWING YOUNGER RIDERS TO EXPLORE THE POSSIBILITIES OF A GYRO EQUIPPED BIKE, RIGHT OUT OF THE BOX.

WE ALWAYS PRIDE OURSELVES IN TAKING FEEDBACK FROM OUR TEAM RIDERS AND PUTTING IT DIRECTLY INTO THE NEW GENERATION OF WTP BIKES. IT'S FOR THIS REASON THAT YOU WILL FIND GEOMETRY CHANGES INCLUDING STEEPER 75.5 ° HEAD TUBE ANGLES, TALLER 9" STANDOVER HEIGHTS, AND SHORTER 13.2" CHAIN STAYS ON MANY OF THE BIKES. THIS MEANS THE BIKES NOT ONLY LOOK, BUT ALSO RIDE EXACTLY LIKE THE ONES OUR PRO'S ARE RUNNING. 2017 SEES A WHOLE NEW LEVEL OF VIBRANT, ORIGINAL AND EYE-CATCHING COLOR SCHEMES; FROM THE NEON YELLOW TIRES OF THE **CURSE** TO THE BEAUTIFUL TRANSLUCENT HONEY GOLD ON THE **TRUST**. THE CAREFULLY CONSIDERED COLOR COMBINATIONS AND FINISHES ARE ONE THING THAT ALWAYS SETS WTP BIKES APART FROM THE CROWD.

THE **REASON** AND THE **ZODIAC** BIKES WERE A HUGE HIT LAST YEAR, AND THE 2017 VERSIONS RETURN WITH PLENTY OF NEW FEATURES TO KEEP THE STREET RIDERS HAPPY. 2017 ALSO BRINGS A NEW BALANCE TO THE COLLECTION WITH THE ADDITION OF A FULLY PARK FOCUSED **VERSUS** MODEL, COMPLETE WITH *SALTPLUS ROTOR SYSTEM*, RESPONSIVE PARK GEOMETRY AND A MESMERIZING HOLOMATIC SPECTRAL SILVER PAINT FINISH. WE HAVEN'T FORGOTTEN ABOUT THE TRAILS RIDERS EITHER, THE **VOLTA** STEPS UP TO THE PLATE AS OUR HIGH END TRAILS/CONCRETE INFLUENCED SETUP AND COMES IN A LONGER 21.15" SIZE, AND BORROWS MANY OF THE FEATURES, GEOMETRY AND COMPONENTS FOUND ON OUR **PATROL** AFTERMARKET RANGE. THE MUCH LOVED **AVENGER** AND **ATLAS** BIKES ARE BOTH BACK FOR 2017 IN TWO FIERCE NEW COLOUR SCHEMES THAT ARE BOUND TO TURN HEADS WHEREVER YOU RIDE.

YOU WON'T BE SURPRISED TO FIND THERE'S NO SHORTAGE OF NEW AND INNOVATIVE AFTERMARKET PRODUCTS SPEC'D ON THE BIKES. STARTING WITH THE 2.35" *TRACER TIRE* AND *EX GRIPS* FROM SALT ON THE ENTRY-LEVEL BIKES, ALL THE WAY THROUGH TO THE *MERRITT BRIAN FOSTER FT1 TIRES* AND *ÉCLAT AK NYLON SPROCKET GUARD* FOUND ON THE **VOLTA** AND **ZODIAC** BIKES, THAT MAGIC WTP TOUCH HAS NEVER BEEN SO PRESENT. THE **ENVY** IS ALWAYS SOMETHING SPECIAL, AND THIS YEAR THE BIKE COMES WITH *BRUNO HOFFMANN SIGNATURE "PREDATOR" TIRES* AND *BRUNO HOFFMANN SIGNATURE GRIPS* FROM ÉCLAT, AS WELL AS HIGH-END WTP COMPONENTS LIKE THE 12 MM FEMALE BOLT *SUPREME HUBS* AND OUR TEAM PROVEN 2.5PC *LEGACY CRANKS*.

WE'RE INCREDIBLY PROUD AND EXCITED BY THE END RESULT OF ALL THE HARD WORK THAT WENT INTO THE 2017 **WETHEPEOPLE** COMPLETE BIKE COLLECTION. PLEASE TAKE THE TIME TO BROWSE THE FOLLOWING PREVIEW OF WHAT'S TO COME IN 2017.

PLEASE NOTE: THE BIKES FEATURED IN THIS PREVIEW PDF ARE RENDERING CONCEPT IMAGES ONLY. FINAL COLOURS, FINISHES AND COMPONENT SPECS MAY BE SUBJECT TO CHANGE AND PRODUCTION BIKES MAY APPEAR DIFFERENT.

A photograph of two BMX riders at a skatepark. The rider in the foreground is wearing a black helmet with 'VANS' and 'GSPORT' logos, a striped tank top, and dark shorts. The rider in the background is wearing a black t-shirt, blue jeans, and a black cap. They are both on their bikes, positioned on a concrete ledge. The background features a graffiti-covered wall with the words 'YOU' and 'THE PIGS' visible, and two white buckets on a ledge. The overall scene is outdoors with a chain-link fence and some foliage in the distance.

WETHEPEOPLE

COMPLETE BIKES 2017 PREVIEW

PRIME

—
W.T.P
—

SIDE VIEW

METALLIC RED 12 INCH

COMPLETE BIKES 2017 PREVIEW

Sfr. 399.00



PRIME

W.T.P

SPECS

ALPHA SERIES | 12 INCH

COMPLETE BIKES 2017 PREVIEW



METALLIC RED

W1798A

FRAME GEOMETRY

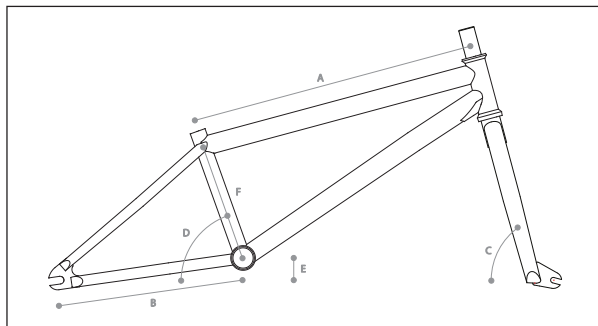

BAR GEOMETRY

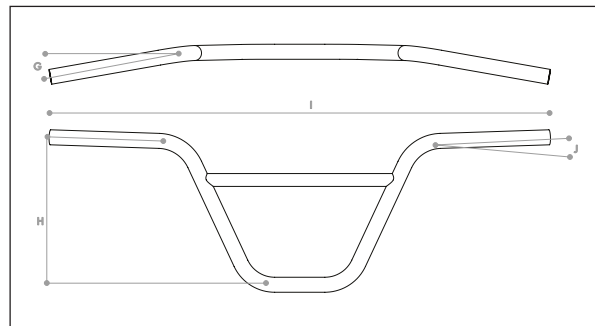

A	TOP TUBE LENGTH	12"
B	CHAIN STAY LENGTH	9.4"
C	HEAD TUBE ANGLE	72 °
D	SEAT TUBE ANGLE	71 °
E	BOTTOM BRACKET HEIGHT	7.4"
F	STANDOVER HEIGHT	5.3"

G	BAR BACKSWEEP	10 °
H	BAR RISE	5.7"
I	BAR WIDTH	20.25"
J	BAR UPSWEEP	2.5 °



FRAME	1020 HI-TEN
FORK	SALT "PRIME" FORK, 1020 HI-TEN, 1PC FORMED CRMO STEERER, 28 MM OFFSET
BARS	1020 HI-TEN
GRIPS	WETHEPEOPLE "ARROW 115" VEX COMPOUND GRIPS
STEM	SALT "PRIME" TOP LOADING STEM, 33 MM REACH
HEADSET	SALT "AM" A-HEADSET, 1" LOOSE BALL
GYRO	NO
LEVER	SALT "EASY REACH" ALLOY BRAKE LEVERS
BRAKES	SALT "AM" ALLOY CALIPER BRAKE FRONT & SALT "AM" V-BRAKE REAR
CRANKS	SALT "PRIME" ALLOY 3PC CRANK 92 MM, 12 SPLINE
BB	SALT "EURO" SEALED BEARING
PEDALS	SALT "PRIME" NYLON / FIBERGLASS PEDALS
CHAIN	SALT "AM" CHAIN, 510H TYPE
SPROCKET	SALT "PRIME" 6061 T6 ALLOY, 23T SPROCKET
DRIVER	9T, 1PC CASSETTE DRIVER, SEALED BEARING / FOR USA MARKET 9T, 1PCS COASTER BRAKE DRIVER
FRONT HUB	SALT "PRIME" ALLOY HUB, LOOSE BALL 3/8"S, 16H
REAR HUB	SALT "AM" CASSETTE HUB, SEMI SEALED, 9T, 3/8"S AXLE, 16H / FOR USA MARKET ALLOY COASTER BRAKE HUB
HUBGUARDS	-
FRONT RIM	SALT "PRIME" RIM, STRAIGHT SINGLE WALL, 16H
REAR RIM	SALT "PRIME" RIM, STRAIGHT SINGLE WALL, 16H
SEAT	WETHEPEOPLE "PRIME" COMBO SEAT
SEAT POST	-
SEAT CLAMP	INTEGRATED SEAT CLAMP
TIRES	"HELIX" 2.125" FRONT & REAR
PEGS	SALT "AM" 32 MM X 85MM STEEL PEGS (1 PAIR)
WEIGHT	TBC

SEED

W.T.P

SIDE VIEW

GLOSSY BLACK 16 INCH

COMPLETE BIKES 2017 PREVIEW

Sfr .449.00



SEED		<hr/> W·T·P <hr/>
SPECS		
ALPHA SERIES	16 INCH	
COMPLETE BIKES 2017 PREVIEW		



GLOSSY BLACK

W1798B

FRAME GEOMETRY

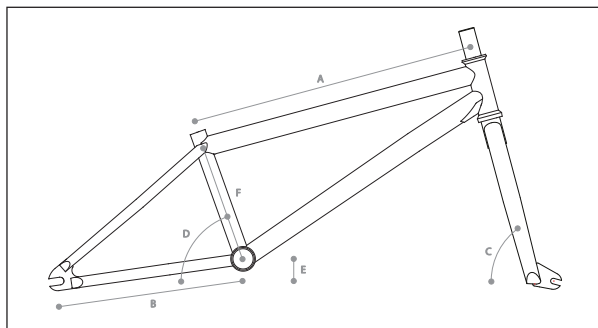

BAR GEOMETRY

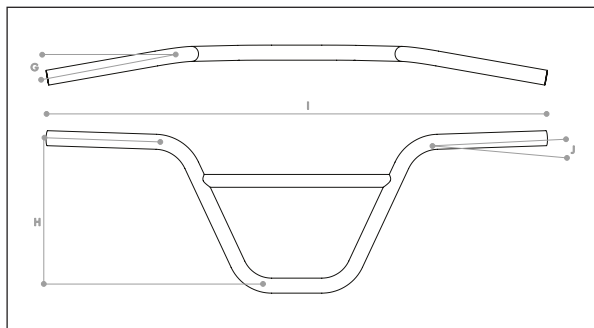

A	TOP TUBE LENGTH	15.75"
B	CHAIN STAY LENGTH	11"
C	HEAD TUBE ANGLE	75 °
D	SEAT TUBE ANGLE	71.5 °
E	BOTTOM BRACKET HEIGHT	9.75"
F	STANDOVER HEIGHT	6.65"

G	BAR BACKSWEEP	10 °
H	BAR RISE	6.75"
I	BAR WIDTH	23.6"
J	BAR UPSWEEP	3 °



FRAME	1020 HI-TEN
FORK	SALT "JUNIOR" FORK, 1020 HI-TEN, 4130 CRMO STEERER, 28 MM OFFSET
BARS	1020 HI-TEN
GRIPS	WETHEPEOPLE "ARROW 115" VEX COMPOUND GRIPS
STEM	SALT "JUNIOR" TOP LOADING STEM, 40 MM REACH
HEADSET	SALT "AM" A-HEADSET, LOOSE BALL
GYRO	HOLES FOR REMOVABLE GYRO TABS
LEVER	SALT "JUNIOR" ALLOY BRAKE LEVER
BRAKES	SALT "AM" ALLOY CALIPER BRAKE FRONT / SALT "AM" ALLOY U-BRAKE REAR
CRANKS	SALT "JUNIOR" TUBULAR 3PC "TSS" CRANK CRMO 140 MM, 8 SPLINE
BB	SALT "SPANISH" 19 MM, PRESS FIT, SEALED BEARING
PEDALS	SALT "JUNIOR PRO" NYLON / FIBERGLASS PEDALS
CHAIN	SALT "AM" CHAIN, 510H TYPE
SPROCKET	SALT "PRO" 6061 T6 ALLOY, 25T SPROCKET
DRIVER	10T, 1PC CASSETTE DRIVER, SEALED BEARING
FRONT HUB	SALT "AM" ALLOY HUB, LOOSE BALL 3/8"S AXLE, 28H
REAR HUB	SALT "AM" CASSETTE HUB, SEMI SEALED, 10T, 3/8"S, 28H
HUBGUARDS	-
FRONT RIM	SALT "VALON" RIM, STRAIGHT SINGLE WALL, 28H
REAR RIM	SALT "VALON" RIM, STRAIGHT SINGLE WALL, 28H
SEAT	WETHEPEOPLE "SEED" COMBO SEAT
SEAT POST	-
SEAT CLAMP	INTEGRATED SEAT CLAMP
TIRES	SALT "STRIKE" 2.2" FRONT & REAR
PEGS	SALT "AM" 32 MM X 85 MM STEEL PEGS (1 PAIR)
WEIGHT	TBC

CURSE

W.T.P

SIDE VIEW

MATT STEEL GREY 18 INCH

COMPLETE BIKES 2017 PREVIEW

Sfr. 489.00
ROTOR Sfr. 499.00



RotorBrake System



CURSE		<hr/> W·T·P <hr/>
SPECS		
ALPHA SERIES	18 INCH	
COMPLETE BIKES 2017 PREVIEW		



MATT BLACK **W1798E**



METALLIC RED **W1798C**



MATT STEEL GREY **W1798D**

FRAME GEOMETRY

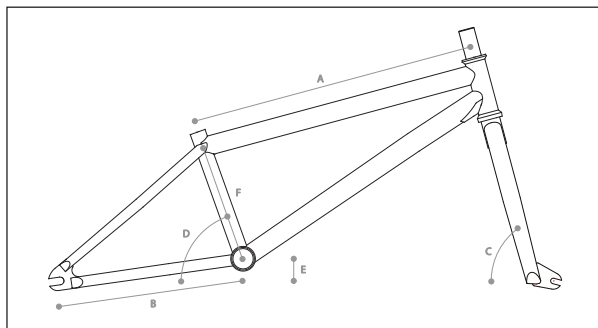

BAR GEOMETRY

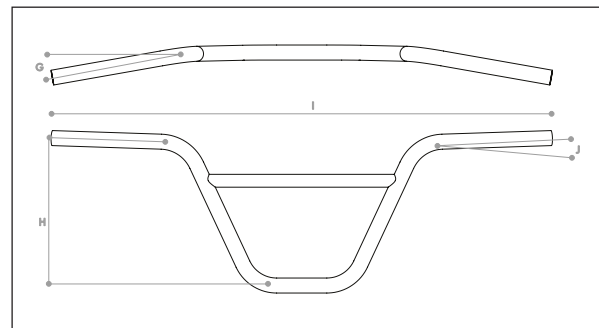

A	TOP TUBE LENGTH	18"
B	CHAIN STAY LENGTH	12.2"
C	HEAD TUBE ANGLE	75 °
D	SEAT TUBE ANGLE	71.5 °
E	BOTTOM BRACKET HEIGHT	10.75 °
F	STANDOVER HEIGHT	7.5"

G	BAR BACKSWEEP	10 °
H	BAR RISE	7.9"
I	BAR WIDTH	26.5"
J	BAR UPSWEEP	3 °



FRAME	4130 CRMO DOWN TUBE, 1020 HI-TEN
FORK	SALT "AM 18" FORK, 1020 HI-TEN, 4130 CRMO STEERER, 28 MM OFFSET
BARS	1020 HI-TEN
GRIPS	WETHEPEOPLE "ARROW 146" VEX COMPOUND GRIPS
STEM	SALT "JUNIOR" TOP LOADING STEM, 40 MM REACH
HEADSET	SALT "PRO" INT. HEADSET, SEALED BEARING
GYRO	CURSE WITHOUT ROTOR / CURSE FS WITH SALT "AM" ROTOR
LEVER	SALT "AM" ALLOY BRAKE LEVER
BRAKES	SALT "AM" ALLOY U-BRAKE REAR
CRANKS	SALT "ROOKIE" TUBULAR 3PC CRANK CRMO 152 MM, 8 SPLINE
BB	SALT "SPANISH" 19 MM, PRESS FIT, SEALED BEARING
PEDALS	ÉCLAT "SURGE" NYLON / FIBERGLASS PEDALS
CHAIN	SALT "AM" CHAIN, 510H TYPE
SPROCKET	SALT "AM" STEEL 25T SPROCKET
DRIVER	9T, 1PC CASSETTE DRIVER, SEALED BEARING
FRONT HUB	SALT "AM" ALLOY HUB, LOOSE BALL 3/8"S AXLE, 28H
REAR HUB	SALT "AM" CASSETTE HUB, FULL SEALED, 9T, 14 MM AXLE, 28H
HUBGUARDS	-
FRONT RIM	SALT "VALON" RIM, STRAIGHT SINGLE WALL, 28H
REAR RIM	SALT "VALON" RIM, STRAIGHT SINGLE WALL, 28H
SEAT	WETHEPEOPLE "CURSE 18" PIVOTAL SEAT
SEAT POST	SALT "AM" PIVOTAL SEAT POST
SEAT CLAMP	SALT "AM" ALLOY SEAT CLAMP
TIRES	SALT "TRACER" TIRES 2.2" FRONT & REAR
PEGS	SALT "AM" 35 MM X 89 MM STEEL PEGS (1 PAIR)
WEIGHT	TBC

CURSE

W.T.P

SIDE VIEW

MATT STEEL GREY 20 INCH

COMPLETE BIKES 2017 PREVIEW

Sfr. 499.00



CURSE

W.T.P

SPECS

ICON SERIES 20 INCH

COMPLETE BIKES 2017 PREVIEW



MATT STEEL GREY

W1798F

FRAME GEOMETRY

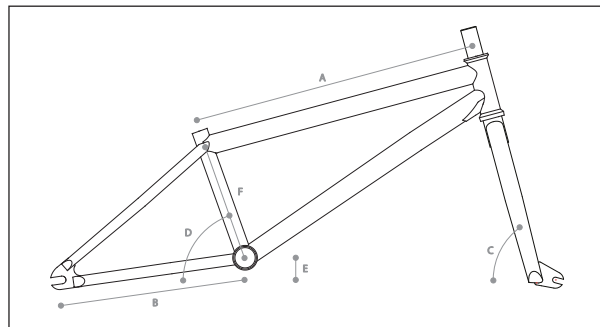

BAR GEOMETRY

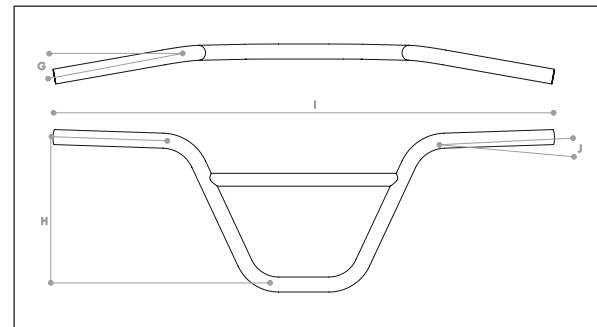

A	TOP TUBE LENGTH	20.25"
B	CHAIN STAY LENGTH	13.2"
C	HEAD TUBE ANGLE	75 °
D	SEAT TUBE ANGLE	71.5 °
E	BOTTOM BRACKET HEIGHT	11.75 °
F	STANDOVER HEIGHT	8.25"

G	BAR BACKSWEEP	11 °
H	BAR RISE	8.6"
I	BAR WIDTH	28.75"
J	BAR UPSWEEP	2 °



FRAME	4130 CRMO DOWN TUBE, 1020 HI-TEN
FORK	SALT "AM 20" FORK, 1020 HI-TEN, 4130 CRMO STEERER, 28 MM OFFSET
BARS	1020 HI-TEN
GRIPS	WETHEPEOPLE "ARROW 146" VEX COMPOUND GRIPS
STEM	SALT "PRO" TOP LOADING STEM, 50 MM REACH
HEADSET	SALT "PRO" INT. HEADSET, SEALED BEARING
GYRO	CURSE WITHOUT ROTOR / CURSE FS WITH SALT "AM" ROTOR
LEVER	SALT "AM" ALLOY BRAKE LEVER
BRAKES	SALTPLUS "MOTO XL" ALLOY U-BRAKE-REAR
CRANKS	SALT "ROOKIE" TUBULAR 3PC CRANK CRMO 165 MM, 8 SPLINE
BB	SALT "MID" 19 MM, PRESS FIT, SEALED BEARING
PEDALS	ÉCLAT "SURGE" NYLON / FIBERGLASS PEDALS
CHAIN	SALT "AM" CHAIN, 510H TYPE
SPROCKET	SALT "AM" STEEL 25T SPROCKET
DRIVER	9T, 1PC CASSETTE DRIVER, SEALED BEARING
FRONT HUB	SALT "AM" ALLOY HUB, LOOSE BALL 3/8" S AXLE, 36H
REAR HUB	SALT "AM" CASSETTE HUB, FULL SEALED, 9T, 14 MM AXLE, 36H
HUBGUARDS	-
FRONT RIM	SALT "VALON" RIM, STRAIGHT SINGLE WALL, 36H
REAR RIM	SALT "VALON" RIM, STRAIGHT SINGLE WALL, 36H
SEAT	WETHEPEOPLE "CURSE 20" MID PADDED PIVOTAL SEAT
SEAT POST	SALT "AM" PIVOTAL SEAT POST
SEAT CLAMP	SALT "AM" ALLOY SEAT CLAMP
TIRES	SALT "TRACER" TIRES 2.35" FRONT & REAR
PEGS	SALT "AM" 35 MM X 89 MM STEEL PEGS (1 PAIR)
WEIGHT	TBC

JUSTICE

W·T·P

SIDE VIEW

TRANSLUCENT TEAL 20 INCH

COMPLETE BIKES 2017 PREVIEW

Sfr. 569.00



JUSTICE

SPECS

ICON SERIES 20 INCH

COMPLETE BIKES 2017 PREVIEW

W.T.P



METALLIC NAVY BLUE **W1798G**

TRANSLUCENT TEAL **W1798H**

FRAME GEOMETRY

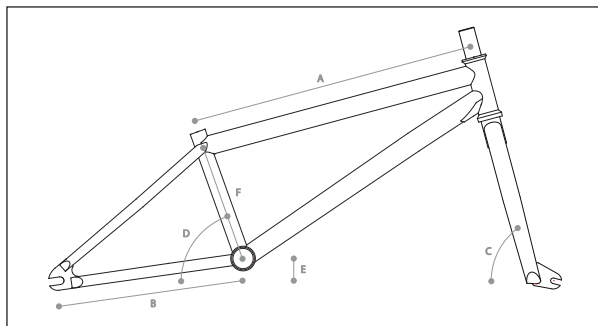

BAR GEOMETRY

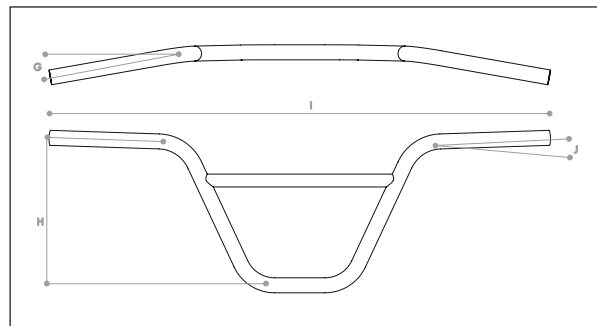

A	TOP TUBE LENGTH	20.5" 21"
B	CHAIN STAY LENGTH	13.5"
C	HEAD TUBE ANGLE	75 °
D	SEAT TUBE ANGLE	71 °
E	BOTTOM BRACKET HEIGHT	11.75 °
F	STANDOVER HEIGHT	8.6" 9"

G	BAR BACKSWEEP	12 °
H	BAR RISE	9"
I	BAR WIDTH	9"
J	BAR UPSWEEP	2 °



FRAME	4130 CRMO DT, TT, TAPERED SS AND CS, WITH REMOVABLE BRAKE PIVOTS & GUIDES
FORK	SALT "AM 20" FORK, 1020 HI-TEN, 4130 CRMO STEERER, 33MM OFFSET
BAR	1020 HI-TEN
GRIPS	SALT "EX" GRIPS
STEM	SALT "COMP" TOP LOADING STEM, 50 MM REACH
HEADSET	SALT "PRO" INT. HEADSET, SEALED BEARING
GYRO	HOLES FOR REMOVABLE GYRO TABS
LEVER	SALT "MOTO" ALLOY BRAKE LEVER
BRAKES	ÉCLAT "TALON" ALLOY U-BRAKE-REAR
CRANKS	SALT "EX" TUBULAR 3PC "TSS" CRANK CRMO 170 MM, 8 SPLINE
BB	SALT "MID" 19 MM, PRESS FIT, SEALED BEARING
PEDALS	SALTPLUS "STEALTH" LOOSE BALL, NYLON / FIBERGLASS PEDALS
CHAIN	SALT "AM" CHAIN, 510H TYPE
SPROCKET	SALT "AM" STEEL 26T SPROCKET
DRIVER	9T, 1PC CASSETTE DRIVER, SEALED BEARING
FRONT HUB	SALT "AM" ALLOY HUB, LB, 3/8"S FEMALE BOLT, 36H
REAR HUB	SALT "EX" CASSETTE HUB, FULL SEALED, 9T, 14 MM AXLE, 36H
HUBGUARDS	-
FRONT RIM	SALT "VALON" RIM, STRAIGHT SINGLE WALL, 36H
REAR RIM	SALTPLUS "SUMMIT" STRAIGHT DOUBLE WALL RIM, 36H
SEAT	WETHEPEOPLE "JUSTICE" MID PADDED TRIPOD SEAT
SEAT POST	SALT "AM" ALLOY TRIPOD POST
SEAT CLAMP	INTEGRATED SEAT CLAMP
TIRES	SALTPLUS "STING" 2.4" FRONT / 2.3" REAR
PEGS	SALT "AM" 35 MM X 89 MM STEEL PEGS (1 PAIR)
WEIGHT	TBC

REASON		<hr/> W·T·P <hr/>
SIDE VIEW		
MATT AQUA BLUE	20 INCH	
COMPLETE BIKES 2017 PREVIEW		

	Sfr. 599.00
FREECOASTER	Sfr. 629.00



REASON		<hr/> W·T·P <hr/>
SPECS		
ICON SERIES	20 INCH	
COMPLETE BIKES 2017 PREVIEW		



MATT BLACK

W1798I



MATT AQUA BLUE

W1798J



FRAME	4130 CRMO DT, TT & CS, TAPERED SS AND CS, WITH REMOVABLE BRAKE PIVOTS & GUIDES
FORK	SALTPLUS "EX" FORK, FULL 4130 CRMO, 1PC FORMED CRMO STEERER, 28 MM OFFSET
BARS	FULL 4130 CRMO BAR
GRIPS	SALTPLUS "XL" VEX COMPOUND, FLANGELESS GRIPS
STEM	SALT "PRO" TOP LOADING STEM, 50 MM REACH
HEADSET	SALT "PRO" INT. HEADSET, SEALED BEARING
GYRO	HOLES FOR REMOVABLE GYRO TABS
LEVER	SALT "MOTO" ALLOY BRAKE LEVER
BRAKES	ÉCLAT "TALON" ALLOY U-BRAKE-REAR
CRANKS	SALT "EX" TUBULAR 3PC "TSS" CRANK CRMO 165 MM, 8 SPLINE
BB	SALT "MID" 19 MM, PRESS FIT, SEALED BEARING
PEDALS	SALTPLUS "STEALTH" LOOSE BALL, NYLON / FIBERGLASS PEDALS
CHAIN	SALT "AM" CHAIN, 510H TYPE
SPROCKET	SALT "PRO" 6061-T6 ALLOY, 26T SPROCKET
DRIVER	9T, 1PC CASSETTE DRIVER, SEALED BEARING
FRONT HUB	SALT "EX" HUB, SB, 3/8"S FEMALE BOLTS, 36H
REAR HUB	SALT "EX" CASSETTE HUB, FULL SEALED, 9T, 14 MM AXLE, 36H
HUBGUARDS	SALTPLUS "PRO" NYLON/FIBREGLASS FRONT & REAR HUBGUARDS
FRONT RIM	SALTPLUS "SUMMIT" STRAIGHT DOUBLE WALL RIM, 36H
REAR RIM	SALTPLUS "SUMMIT" STRAIGHT DOUBLE WALL RIM, 36H
SEAT	WETHEPEOPLE "REASON" FAT PADDED TRIPOD SEAT
SEAT POST	SALT "AM" ALLOY TRIPOD POST
SEAT CLAMP	INTEGRATED SEAT CLAMP
TIRES	SALTPLUS "STING" 2.4" FRONT / 2.3" REAR
PEGS	SALT "AM" 35 MM X 89 MM STEEL PEGS (1 PAIR)
WEIGHT	TBC

FRAME GEOMETRY

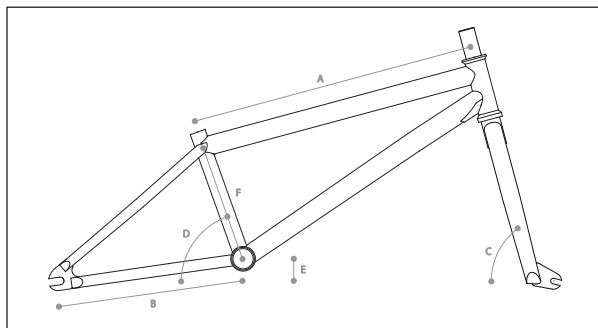

BAR GEOMETRY

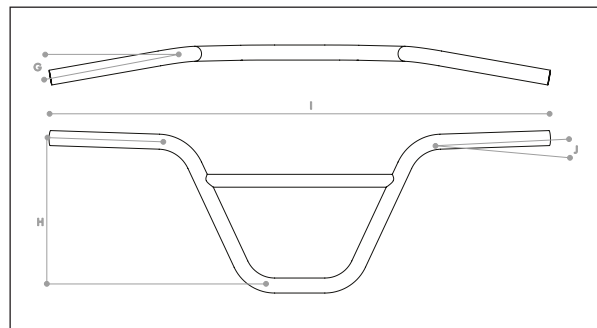

A	TOP TUBE LENGHT	20.75"
B	CHAIN STAY LENGTH	13.2"
C	HEAD TUBE ANGLE	75 °
D	SEAT TUBE ANGLE	71 °
E	BOTTOM BRACKET HEIGHT	11.75"
F	STANDOVER HEIGHT	8.75"

G	BAR BACKSWEEP	12 °
H	BAR RISE	9"
I	BAR WIDTH	29.5"
J	BAR UPSWEEP	2 °

CRYSIS

W.T.P

SIDE VIEW

METALLIC COPPER 20 INCH

COMPLETE BIKES 2017 PREVIEW

Sfr . 699 . 00



CRYSIS

W.T.P

SPECS

MASTER SERIES 20 INCH

COMPLETE BIKES 2017 PREVIEW



MATT BLACK

W1698L



METALLIC COPPER

W1798K



FRAME GEOMETRY

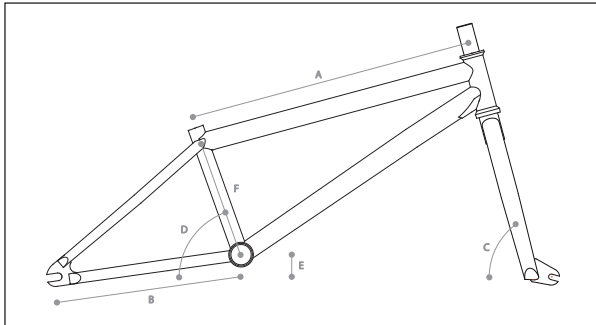

BAR GEOMETRY

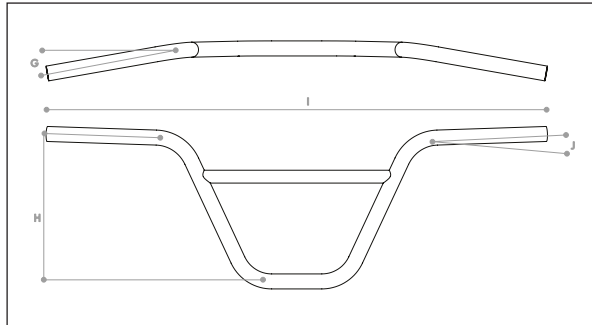

A	TOP TUBE LENGTH	20.5" 21"
B	CHAIN STAY LENGTH	13.2"
C	HEAD TUBE ANGLE	75.5 °
D	SEAT TUBE ANGLE	71 °
E	BOTTOM BRACKET HEIGHT	11.75"
F	STANDOVER HEIGHT	8.75" 9"

G	BAR BACKSWEEP	12 °
H	BAR RISE	9"
I	BAR WIDTH	29.5"
J	BAR UPSWEEP	2 °



FRAME	4130 FULL CRMO FRAME, TAPERED SS & CS REMOVABLE PIVOTS & GUIDES
FORK	SALTPLUS "EX" FORK, FULL 4130 CRMO, 1PC FORMED CRMO STEERER, 28 MM OFFSET
BARS	FULL 4130 CRMO BAR
GRIPS	WETHEPEOPLE "HILT XL" VEX COMPOUND, FLANGELESS GRIPS
STEM	SALTPLUS "CENTER" TOP LOADING STEM, 50 MM REACH
HEADSET	SALT "PRO" INT. HEADSET, SEALED BEARING
GYRO	HOLES FOR REMOVABLE GYRO TABS
LEVER	SALT "MOTO" ALLOY BRAKE LEVER
BRAKES	ÉCLAT "TALON" ALLOY U-BRAKE-REAR
CRANKS	SALT "COMP" TUBULAR 3PC "TSS" CRANK CRMO 170 MM, 8 SPLINE
BB	SALT "MID" 19 MM, PRESS FIT, SEALED BEARING
PEDALS	ÉCLAT "SLASH" NYLON / FIBERGLASS PEDALS
CHAIN	SALT "AM" CHAIN, 510H TYPE
SPROCKET	SALTPLUS "TRIDENT" 6061-T6 ALLOY, 25T SPROCKET
DRIVER	9T, 1PC CASSETTE DRIVER, SEALED BEARING
FRONT HUB	SALT "EX" HUB, SB, 3/8"S FEMALE BOLTS, 36H
REAR HUB	SALT "EX" CASSETTE HUB, FULL SEALED, 9T, 14 MM AXLE, 36H
HUBGUARDS	SALTPLUS "PRO" NYLON / FIBERGLASS FRONT & REAR HUBGUARDS
FRONT RIM	ÉCLAT "TRIPPIN XL" STRAIGHT DOUBLE WALL RIM, 36H
REAR RIM	ÉCLAT "TRIPPIN XL" STRAIGHT DOUBLE WALL RIM, 36H
SEAT	WETHEPEOPLE "CRYSIS" FAT PADDED PIVOTAL SEAT
SEAT POST	SALT "AM" ALLOY PIVOTAL POST
SEAT CLAMP	INTEGRATED SEAT CLAMP
TIRES	SALTPLUS "STING" 2.4" FRONT / 2.3" REAR
PEGS	SALT "PRO" 38 MM X 109 MM STEEL/NYLON SLEEVE PEGS (1 PAIR)
WEIGHT	TBC

VERSUS

W.T.P

SIDE VIEW

METALLIC LIME GREEN 20 INCH

COMPLETE BIKES 2017 PREVIEW

Sfr. 799.00



Rotor Brake System



VERSUS

W.T.P

SPECS

MASTER SERIES 20 INCH

COMPLETE BIKES 2017 PREVIEW

2016 SPECIFICATION Sfr. 699.00



GLOSSY BLUE

W1698M



METALLIC LIME GREEN

W1798L

FRAME GEOMETRY

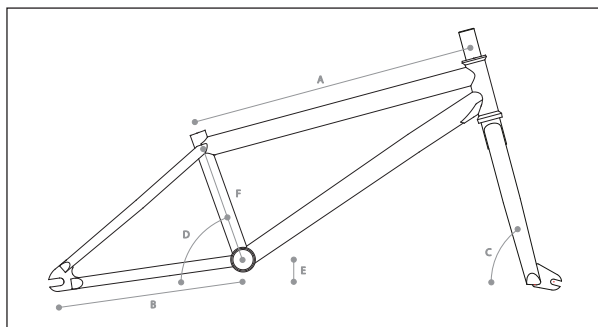

BAR GEOMETRY

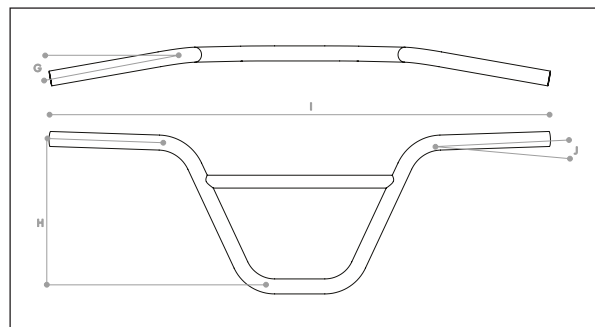

A	TOP TUBE LENGTH	20.75"
B	CHAIN STAY LENGTH	13.2"
C	HEAD TUBE ANGLE	75.25 °
D	SEAT TUBE ANGLE	71 °
E	BOTTOM BRACKET HEIGHT	11.6"
F	STANDOVER HEIGHT	7.75"

G	BAR BACKSWEEP	12 °
H	BAR RISE	9"
I	BAR WIDTH	29.5"
J	BAR UPSWEEP	2 °



FRAME	4130 FULL CRMO, TAPERED SS & CS REMOVABLE PIVOTS & GUIDES
FORK	SALTPLUS "Ex" FORK, FULL 4130 CRMO, 1PC FORMED CRMO STEERER, 28 MM OFFSET
BARS	FULL 4130 CRMO BAR
GRIPS	SALTPLUS "XL" VEX COMPOUND GRIPS
STEM	WETHEPEOPLE "INDEX" FRONT LOADING STEM, 50 MM REACH
HEADSET	SALT "PRO" INT. HEADSET, SEALED BEARING
GYRO	SALTPLUS "Geo" CNC ALLOY ROTOR, SALTPLUS "DUAL" UPPER CABLE
LEVER	SALT "MOTO" ALLOY BRAKE LEVER
BRAKES	ÉCLAT "TALON" ALLOY U-BRAKE-REAR
CRANKS	SALTPLUS "PRO48" (L&R) TUBULAR 3PC CRANK CRMO 170 MM, 48 SPLINE
BB	SALT "MID" 19 MM, PRESS FIT, SEALED BEARING
PEDALS	ÉCLAT "SLASH" NYLON / FIBERGLASS PEDALS
CHAIN	SALT "AM" CHAIN, 510H TYPE
SPROCKET	SALTPLUS "CENTER" 6061-T6 ALLOY, CNC, 25T SPROCKET
DRIVER	9T, 1PC CASSETTE DRIVER, SEALED BEARING
FRONT HUB	SALT "Ex" HUB, SB, 3/8"S FEMALE BOLTS, 36H
REAR HUB	SALT "Ex" CASSETTE HUB, SB, 9T, HOLLOW 14 MM AXLE, 36H
HUBGUARDS	SALTPLUS "PRO" NYLON / FIBREGLASS FRONT & REAR HUBGUARDS
FRONT RIM	SALTPLUS "SUMMIT" STRAIGHT DOUBLE WALL RIM, 36H
REAR RIM	SALTPLUS "SUMMIT" STRAIGHT DOUBLE WALL RIM, 36H
SEAT	WETHEPEOPLE "VERSUS" SLIM PADDED TRIPOD SEAT
SEAT POST	SALT "AM" ALLOY TRIPOD POST
SEAT CLAMP	INTEGRATED SEAT CLAMP
TIRES	SALTPLUS "PITCH FLOW" TIRES 2.25" FRONT & REAR
PEGS	SALT "PRO" 38 MM X 109 MM STEEL / NYLON SLEEVE PEGS (1 PAIR)
WEIGHT	TBC

TRUST

W.T.P

SIDE VIEW

TRANSLUCENT HONEY GOLD 20 INCH

COMPLETE BIKES 2017 PREVIEW

Sfr. 779.00



TRUST

W.T.P

SPECS

PRO SERIES 20 INCH

COMPLETE BIKES 2017 PREVIEW



GREY C.P.

W1698N



HONEY GOLD

W1798M

FRAME GEOMETRY

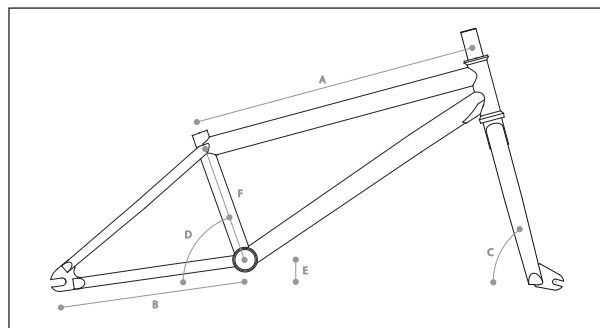

BAR GEOMETRY

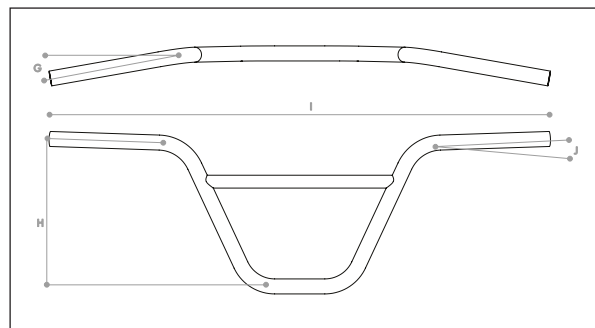

A	TOP TUBE LENGTH	20.5" 21"
B	CHAIN STAY LENGTH	13.5"
C	HEAD TUBE ANGLE	75 °
D	SEAT TUBE ANGLE	70 °
E	BOTTOM BRACKET HEIGHT	11.75"
F	STANDOVER HEIGHT	8.6" 9"

G	BAR BACKSWEEP	12 °
H	BAR RISE	9"
I	BAR WIDTH	29.5"
J	BAR UPSWEEP	2 °



FRAME	4130 FULL CRMO, TAPERED SS & CS, REMOVABLE PIVOTS & GUIDES, INVEST CAST DROPOUT WITH INTG. CHAIN TENSIONER
FORK	SALTPLUS "Ex" FORK, FULL 4130 CRMO, 1PC FORMED CRMO STEERER 33 MM OFFSET
BARS	FULL 4130 CRMO BAR
GRIPS	WETHEPEOPLE "HILT XL" VEX COMPOUND, FLANGELESS GRIPS
STEM	SALTPLUS "FIELD" CNC ALLOY TOP LOADING STEM, 50 MM REACH
HEADSET	SALT "PRO" INT. HEADSET, SEALED BEARING
GYRO	HOLES FOR REMOVABLE GYRO TABS
LEVER	SALTPLUS "Geo" HINGED ALLOY BRAKE LEVER
BRAKES	SALT "MOTO XL" ALLOY U-BRAKE REAR
CRANKS	SALTPLUS "ELITE" (L&R) TUBULAR 3PC CRANK CRMO 170 MM, 48 SPLINE
BB	SALT "Mid" 19 MM, PRESS FIT, SEALED BEARING
PEDALS	ÉCLAT "SLASH" NYLON / FIBERGLASS PEDALS
CHAIN	SALT "AM" CHAIN, 510H TYPE
SPROCKET	SALTPLUS "TRIDENT" 6061-T6 ALLOY, 26T SPROCKET
DRIVER	9T, 1PC CASSETTE DRIVER, L&R SWITCH DRIVE, SEALED BEARING
FRONT HUB	SALTPLUS "TRAPEZ" HUB, SB, 3/8" S FEMALE BOLTS, 36H
REAR HUB	SALTPLUS "TRAPEZ" CASSETTE HUB, SB, 9T L&R SWITCH DRIVE, 14 MM HOLLOW AXLE, 36H
HUBGUARDS	SALTPLUS "PRO" NYLON / FIBREGLASS FRONT & REAR HUBGUARDS
FRONT RIM	ÉCLAT "TRIPPIN" STRAIGHT DOUBLE WALL RIM, 36H
REAR RIM	ÉCLAT "TRIPPIN" STRAIGHT DOUBLE WALL RIM, 36H
SEAT	WETHEPEOPLE "TRUST" FAT PADDED PIVOTAL SEAT
SEAT POST	SALT "AM" ALLOY PIVOTAL POST
SEAT CLAMP	INTEGRATED SEAT CLAMP
TIRES	ÉCLAT "FIREBALL" 2.4" FRONT & 2.3" REAR
PEGS	SALT "PRO" STEEL / NYLON SLEEVE PEGS (1 PAIR)
WEIGHT	TBC

ZODIAC

W.T.P

SIDE VIEW

TRANSLUCENT PURPLE 20 INCH

COMPLETE BIKES 2017 PREVIEW

Sfr . 869 . 00



ZODIAC

W.T.P

SPECS

PRO SERIES

20 INCH

COMPLETE BIKES 2017 PREVIEW



TRANSLUCENT PURPLE **W1798N**

FRAME GEOMETRY

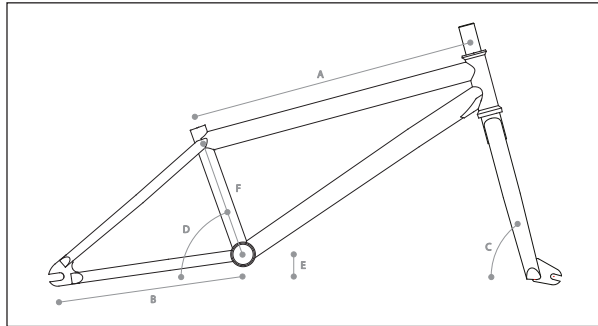

BAR GEOMETRY

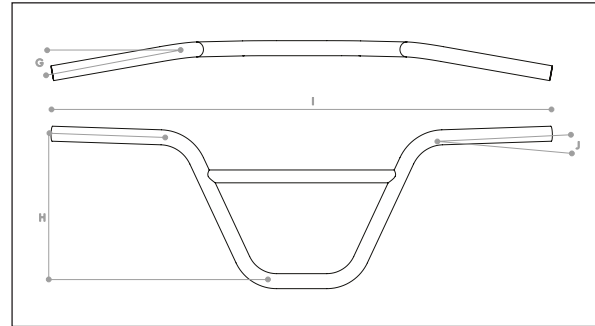

A	TOP TUBE LENGTH	20.75"
B	CHAIN STAY LENGTH	13.2"
C	HEAD TUBE ANGLE	75.5 °
D	SEAT TUBE ANGLE	71 °
E	BOTTOM BRACKET HEIGHT	11.75"
F	STANDOVER HEIGHT	9"

G	BAR BACKSWEEP	11 °
H	BAR RISE	9"
I	BAR WIDTH	29.2"
J	BAR UPSWEEP	3 °



FRAME	4130 FULL CRMO, TAPERED SS & CS, REMOVABLE PIVOTS & GUIDES, INVEST CAST DROPOUT WITH INTG. CHAIN TENSIONER
FORK	WETHEPEOPLE "ZODIAC" FORK, BUTTED SANKO TUBING, CNC STEERER, 28 MM OFFSET, CR-MO DROPOUTS
BARS	FULL 4130 CRMO 4PC BAR
GRIPS	WETHEPEOPLE "HILT XL" VEX COMPOUND, FLANGELESS GRIPS
STEM	ÉCLAT "DUNE" 6061 T6 FULL CNC, TOP LOADING STEM, 50 MM REACH
HEADSET	SALTPLUS "ECHO" INT. HEADSET, SEALED BEARING
GYRO	HOLES FOR REMOVABLE GYRO TABS
LEVER	SALTPLUS "Geo" HINGED ALLOY BRAKE LEVER
BRAKES	ÉCLAT "TALON" ALLOY U-BRAKE-REAR
CRANKS	SALTPLUS "ELITE" (L&R) TUBULAR 3PC CRANK CRMO 165 MM, 48 SPLINE
BB	SALT "MID" 19 MM, PRESS FIT, SEALED BEARING
PEDALS	ÉCLAT "SLASH" NYLON / FIBERGLASS PEDALS
CHAIN	SALTPLUS "WARLOCK" HALF-LINK CHAIN
SPROCKET	SALTPLUS "PRO GUARD" 6061-T6 ALLOY, 25T CNC SPROCKET & ÉCLAT "AK" NYLON GUARD
DRIVER	9T, 1PC FREECOASTER DRIVER, SEALED BEARING
FRONT HUB	SALTPLUS "TRAPEZ" HUB, SB, 3/8" S FEMALE BOLTS, 36H
REAR HUB	SALTPLUS "PRO" FREECOASTER HUB, FULL SEALED, 9T, 14 MM AXLE, 36H
HUBGUARDS	SALTPLUS "PRO" NYLON / FIBREGLASS FRONT & REAR HUBGUARDS
FRONT RIM	ÉCLAT "TRIPPIN XL" STRAIGHT DOUBLE WALL RIM, 36H
REAR RIM	ÉCLAT "TRIPPIN XL" STRAIGHT DOUBLE WALL RIM, 36H
SEAT	ÉCLAT "0z V2" FAT PADDED PIVOTAL SEAT
SEAT POST	SALT "AM" PIVOTAL SEAT POST, ALLOY
SEAT CLAMP	INTEGRATED SEAT CLAMP
TIRES	WETHEPEOPLE "STICKIN" 2.4" FRONT / 2.3" REAR
PEGS	-
WEIGHT	TBC

VOLTA

W.T.P

SIDE VIEW

TRANSLUCENT BLACK 20 INCH

COMPLETE BIKES 2017 PREVIEW

Sfr. 999.00



VOLTA

W.T.P

SPECS

ELITE SERIES 20 INCH

COMPLETE BIKES 2017 PREVIEW



TRANSLUCENT BLACK

W17980

BRUSHED BROWN C.P.

W1698P

FRAME GEOMETRY

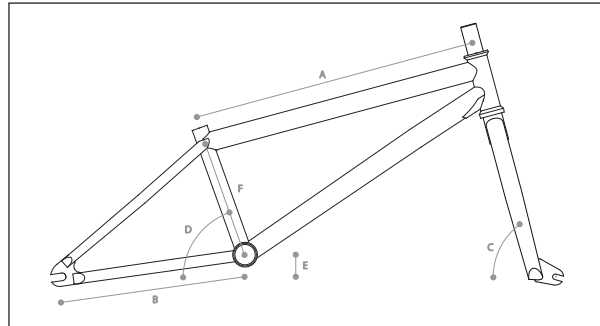

BAR GEOMETRY

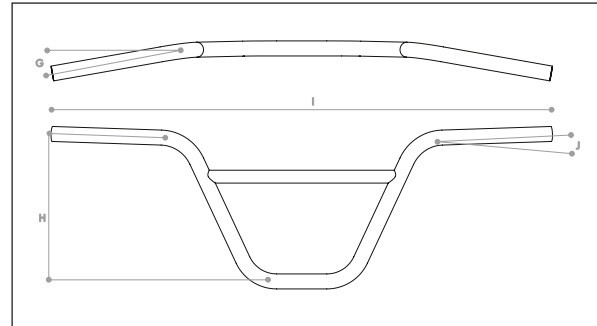

A	TOP TUBE LENGTH	21.15"
B	CHAIN STAY LENGTH	13.75"
C	HEAD TUBE ANGLE	74.25 °
D	SEAT TUBE ANGLE	71 °
E	BOTTOM BRACKET HEIGHT	11.5"
F	STANDOVER HEIGHT	9"

G	BAR BACKSWEEP	12 °
H	BAR RISE	9"
I	BAR WIDTH	29.5"
J	BAR UPSWEEP	2 °



FRAME	4130 FULL SANKO, TAPERED SS & CS, REMOVABLE PIVOTS & GUIDES, INTG. CHAIN TENSIONER
FORK	WETHEPEOPLE "VOLTA" FORK, BUTTED SANKO TUBING, CNC STEERER, 32 MM OFFSET, CR-MO DROPOUTS
BARS	FULL 4130 CRMO BAR
GRIPS	SALTPLUS "XL" VEX COMPOUND GRIPS, WITH FLANGE
STEM	WETHEPEOPLE "PATROL" CNC ALLOY TOP LOADING STEM, 28 MM RISE, 53 MM REACH
HEADSET	SALTPLUS "ECHO" INT. HEADSET, SEALED BEARING
GYRO	HOLES FOR REMOVABLE GYRO TABS
LEVER	SALTPLUS "Geo" HINGED ALLOY BRAKE LEVER
BRAKES	SALTPLUS "MOTO XL" ALLOY U-BRAKE REAR
CRANKS	WETHEPEOPLE "ROYAL", TUBULAR 3PC CRANK CRMO, 175 MM, 48 SPLINE
BB	SALTPLUS "ECHO", MID 19 MM, PRESS FIT, SEALED BEARING
PEDALS	ÉCLAT "CONTRA" NYLON / FIBERGLASS PEDALS, REMOVABLE PINS
CHAIN	ÉCLAT "DIESEL" CHAIN
SPROCKET	WETHEPEOPLE "4STAR" 6061-T6 ALLOY, 28T CNC SPROCKET
DRIVER	9T, 1PC CASSETTE DRIVER, FULL BUSHING
FRONT HUB	ÉCLAT "KOLIBRI" HUB, SB, 3/8" S AXLE, 36H
REAR HUB	ÉCLAT "KOLIBRI" CASSETTE, SB HUB, 9T, 14 MM AXLE, 36H
HUBGUARDS	-
FRONT RIM	SALTPLUS "MESSA" STRAIGHT DOUBLE WALL, FLASH WELDED RIM, 36H
REAR RIM	SALTPLUS "MESSA" STRAIGHT DOUBLE WALL, FLASH WELDED RIM, 36H
SEAT	WTP "VOLTA" SLIM PADDED TRIPOD SEAT
SEAT POST	SALT "AM" ALLOY TRIPOD POST
SEAT CLAMP	INTEGRATED SEAT CLAMP
TIRES	MERRIT "BRIAN FOSTER" 2.35" FRONT & 2.25" REAR
PEGS	-
WEIGHT	TBC

ENVY

—
W·T·P
—

SIDE VIEW

GOLD NICKEL 20 INCH

COMPLETE BIKES 2017 PREVIEW

Sfr.1199.00



ENVY		<hr/> W-T-P <hr/>
SPECS		
ELITE SERIES	20 INCH	
COMPLETE BIKES 2017 PREVIEW		



GOLD NICKEL **W1798P**



GOLD NICKEL **W1798Q**

FRAME GEOMETRY

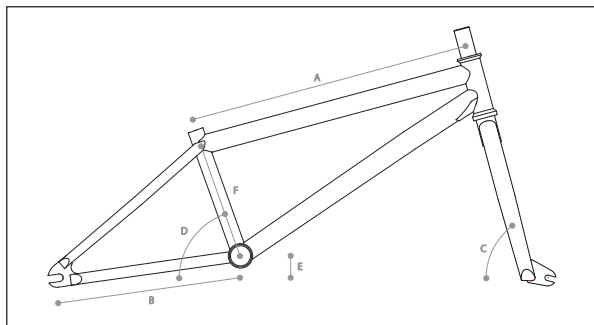

BAR GEOMETRY

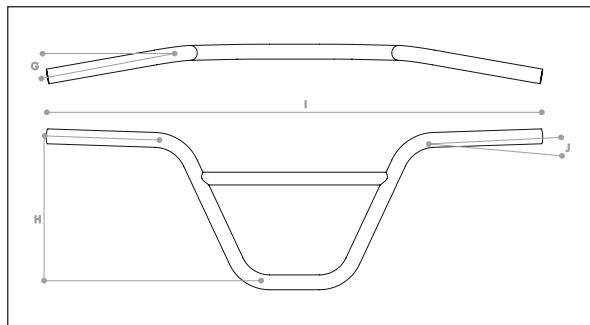

A	TOP TUBE LENGTH	20.6" 21.15"
B	CHAIN STAY LENGTH	13.55"
C	HEAD TUBE ANGLE	75 °
D	SEAT TUBE ANGLE	71 °
E	BOTTOM BRACKET HEIGHT	11.5"
F	STANDOVER HEIGHT	8.75" 9"

G	BAR BACKSWEEP	11 °
H	BAR RISE	9.2"
I	BAR WIDTH	29.25"
J	BAR UPSWEEP	2 °



FRAME	4130 FULL SANKO, TAPERED CS AND SS, REMOVABLE PIVOTS & GUIDES, INTG. CHAIN TENSIONER
FORK	"ENVY" FORK, FULL 4130 SANKO WITH POST LIQUID HEAT-TREATED, 1PC CNC STEERER, 28 MM OFFSET
BARS	"ENVY" BARS FULL 4130 SANKO, POST LIQUID HEAT-TREATED, 25.4 MM CLAMPING
GRIPS	ÉCLAT "BRUNO " VEX COMPOUND GRIPS & INCLUDING ÉCLAT BARENDS
STEM	WETHEPEOPLE "HYDRA" CNC ALLOY TOP LOADING STEM, 25.4 MM CLAMP, 27 MM RISE, 50 MM REACH
HEADSET	SALTPLUS "ECHO" INTEGRATED HEADSET, SEALED BEARING
GYRO	HOLES FOR REMOVABLE GYRO TABS
LEVER	ÉCLAT "SNIPER" HINGED ALLOY BRAKE LEVER, TWO FINGER VERSION
BRAKES	ÉCLAT "TALON" ALLOY U-BRAKE-REAR, WITH ÉCLAT BRAKEPADS
CRANKS	WETHEPEOPLE "LEGACY" 2.5 PC CRANK, CRMO, 170 MM, 48T SPLINE, 22 MM SPINDLE
BB	ÉCLAT "CNC" MID SIZE, PRESS FIT, SEALED BEARING
PEDALS	ÉCLAT "SLASH" NYLON / FIBERGLASS PEDALS
CHAIN	SALTPLUS "WARLOCK" HALF-LINK CHAIN
SPROCKET	WETHEPEOPLE "4Star" 6061-T6 ALLOY, 26T CNC SPROCKET
DRIVER	9T, 1PC CASSETTE DRIVER, L&R SWITCH DRIVE, SEALED BEARING
FRONT HUB	WETHEPEOPLE "SUPREME" HUB, 3/8s" FEMALE BOLTS, 36H
REAR HUB	WETHEPEOPLE "SUPREME" CASSETTE HUB, SB, 9T L&R SWITCH DRIVE, 14MM HOLLOW AXLE, 36H
HUBGUARDS	-
FRONT RIM	ÉCLAT "RAVEN" STRAIGHT, DOUBLE WALL RIM, 36H, FLASH WELDED
REAR RIM	ÉCLAT "RAVEN" STRAIGHT, DOUBLE WALL RIM, 36H, FLASH WELDED
SEAT	ÉCLAT "0z V2" FAT PADDED PIVOTAL SEAT
SEAT POST	WETHEPEOPLE 3D FORGED ALLOY PIVOTAL SEAT POST
SEAT CLAMP	INTEGRATED SEAT CLAMP
TIRES	ÉCLAT "PREDATOR" 2.3" FRONT / 2.3" REAR
PEGS	-
WEIGHT	TBC

ATLAS

SIDE VIEW 24 INCH

GLOSSY DARK GREEN

COMPLETE BIKES 2016 PREVIEW

W·T·P

Sfr. 779.00



ATLAS

W.T.P

SPECS

SPECIAL 24 INCH

COMPLETE BIKES 2016 PREVIEW



GLOSSY DARK GREEN **W1698S**

FRAME GEOMETRY

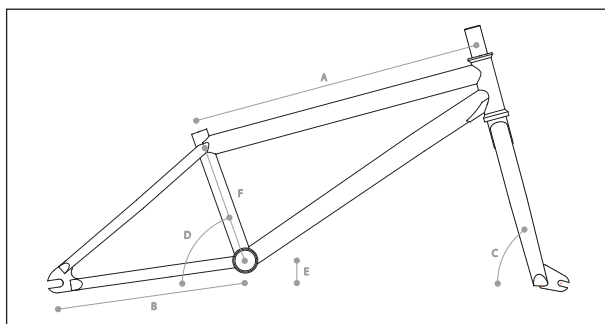

A	TOP TUBE LENGTH	22"
B	CHAIN STAY LENGTH	14.6"
C	HEAD TUBE ANGLE	74°
D	SEAT TUBE ANGLE	72°
E	BOTTOM BRACKET HEIGHT	12.7"
F	STANDOVER HEIGHT	9.7"

BAR GEOMETRY

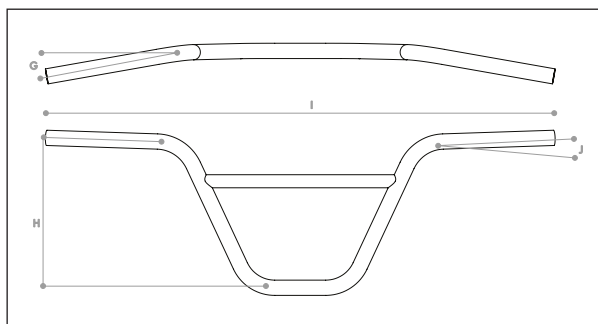

G	BACKSWEEP	12°
H	RISE	7.5"
I	WIDTH	28.1"
J	UPSWEEP	2.5°



FRAME	4130 FULL CRMO, INTG. CHAIN TENSIONER
FORK	SALTPLUS "MAGIC-24" FORK, SANKO TUBING, CNC STEERER, INV. CAST DROPOUTS
BARS	FULL 4130 CRMO BAR
GRIPS	WETHEPEOPLE VEX COMPOUND "HILT" GRIPS
STEM	SALTPLUS "FIELD" TOP LOADING STEM, 50MM REACH
HEADSET	SALT "PRO" INT. HEADSET, SEALED BEARING
GYRO	NO
LEVER	SALT "MOTO" ALLOY BRAKE LEVER
BRAKES	SALTPLUS "GEO" U-BRAKE REAR, INCL. SALTPLUS "PROPELLER" BRAKE PADS
CRANKS	SALTPLUS "PRO48" TUBULAR 3PC CRANK CRMO 175MM, 48 SPLINE
BB	SALT "MID SIZE", PRESS FIT, SEALED BEARING
PEDALS	SALTPLUS "STEALTH" NYLON/FIBREGLASS PEDALS, LOOSE BALL
CHAIN	SALT "AM" CHAIN, 510H TYPE
SPROCKET	SALTPLUS "CENTER" 6061 T6 ALLOY, CNC, 25T SPROCKET
DRIVER	10T, 1PC CASSETTE DRIVER, SEALED BEARING
FRONT HUB	SALT "EXPERT" HUB, SB, 3/8" FEMALE BOLTS, 36H
REAR HUB	SALT "PRO" CASSETTE HUB, SB, 10T, HOLLOW 14MM AXLE, 36H
FRONT RIM	SALTPLUS "SUMMIT" STRAIGHT DOUBLE WALL RIM, 36H
REAR RIM	SALTPLUS "SUMMIT" STRAIGHT DOUBLE WALL RIM, 36H
SEAT	WETHEPEOPLE "ALTAS" SLIM PADDED PIVOTAL SEAT
SEAT POST	SALT "AM" PIVOTAL SEAT POST, ALLOY, 150MM
SEAT CLAMP	INTEGRATED SEAT CLAMP
TIRES	KENDA "SMALL BLOCK 8" TIRES 2.1" FRONT / 1.95"
PEGS	-
WEIGHT	12 KG (26.4 LBS) AS PICTURE

AVENGER

W.T.P

SIDE VIEW 26 INCH

GLOSSY NAVY BLUE

COMPLETE BIKES 2016 PREVIEW

Sfr .849.00



AVENGER

SPECS

SPECIAL 26 INCH

COMPLETE BIKES 2016 PREVIEW

W.T.P



GLOSSY NAVY BLUE **W1698T**

FRAME GEOMETRY

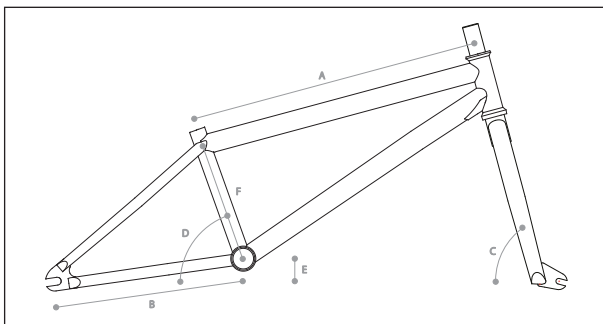

A	TOP TUBE LENGTH	23.15"
B	CHAIN STAY LENGTH	17.15"
C	HEAD TUBE ANGLE	72°
D	SEAT TUBE ANGLE	73°
E	BOTTOM BRACKET DROP	-20MM
F	STANDOVER HEIGHT	14.75"

BAR GEOMETRY

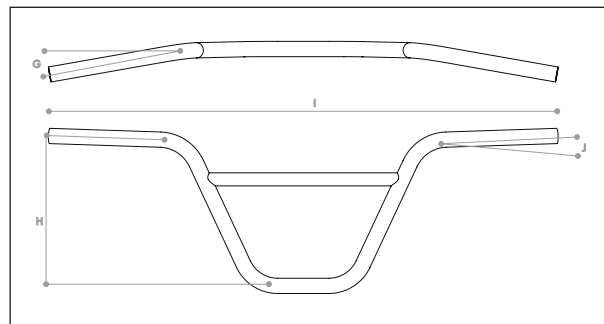

G	BACKSWEEP	15°
H	RISE	6.5"
I	WIDTH	29.9"
J	UPSWEEP	3°



FRAME	WETHEPEOPLE "AVENGER" BEACH CRUISER FRAME, CRMO DOWNTUBE
FORK	WETHEPEOPLE "AVENGER" CRMO FORK
BARS	WETHEPEOPLE "AVENGER" FULL 4130 CRMO BAR
GRIPS	WETHEPEOPLE VEX COMPOUND "HILT" GRIPS
STEM	WETHEPEOPLE "AVENGER" 1" SHAFT STEM
HEADSET	FSA "PRO" A-HEADSET, 1" SEALED BEARING
GYRO	-
LEVER	ALLOY BRAKE LEVER
BRAKES	ALLOY V-BRAKE REAR
CRANKS	SALT "EXPERT" TUBULAR 3PC "TSS" CRANK CRMO 170MM, 8 SPLINE
BB	SALT "AM" USA, SEALED BEARING
PEDALS	WETHEPEOPLE "AVENGER" OLDSCHOOL CAGE DESIGN
CHAIN	SALT "AM" CHAIN, 510H TYPE
SPROCKET	WETHEPEOPLE "AVENGER" CLASSIC LOOK SPROCKET, 33T
DRIVER	SALTPLUS "PRO" FREEWHEEL, 13T
FRONT HUB	WETHEPEOPLE "AVENGER", SB, 3/8" AXLE
REAR HUB	WETHEPEOPLE "AVENGER", SB, 3/8" AXLE
FRONT RIM	WETHEPEOPLE "AVENGER" 26", ALLOY, DOUBLE WALL
REAR RIM	WETHEPEOPLE "AVENGER" 26", ALLOY, DOUBLE WALL
SEAT	WETHEPEOPLE "AVENGER" CLASSIC LOOK RAILED SEAT
SEAT POST	ALLOY, 3D FORGED
SEAT CLAMP	ALLOY SEAT CLAMP
TIRES	KENDA "K-RAD" TIRES 2.3" FRONT & REAR
PEGS	-
WEIGHT	13.8 KG (30.4 LBS) AS PICTURE



Welcome to the 2017 Bombtrack Complete Bike Preview, we are extremely excited to present to you what has been our labor of love this past year. We were blown away by the feedback on last year's range, especially with our representation at the Eurobike and Interbike shows. We feel the momentum with the brand and want to take this in combination with the feedback we received to make the 2017 range, the best so far.

You will see at a glance that the range has expanded, but don't think the existing models have been neglected either, with virtually every bike seeing more than just a cosmetic change.

The track bikes both see an update with the Script gaining a carbon fork and a velodrome focus whilst the Needle now sports the Columbus Dove. The Arise has dropped the v-brakes in favor of discs, and is joined by a flat bar, internal geared sibling that is ideally suited to the urban life. The Hook line is expanded with the addition of the CX-race oriented Hook AL. Sitting slightly above the Hook 2 the new Hook EXT takes the 'road-plus' concept into the gravel world. All-round thru-axles, 2.1" tires and a SRAM Rival-1 hydraulic groupset mean it's able to take on just about anything.

The Tempest also sees an update with a tapered head tube and DT Swiss wheels, as well as gaining a disc brake, thru-axle sibling. The successful introduction of the Beyond last year is built upon by a new 27.5+" variant, which takes bike-packing trips deeper into the wilderness. Back in the urban landscape the new Outlaw combines the latest 'Road Plus' concept with a belt-drive system and Café Racer attitude.

One of our main focuses in developing the new range was to further optimize each model in terms of spec, price and sizing. So take your time as you go through the following pages, as there are a lot of highlights and details you won't want to miss.

"Please note that some parts and finishes shown in the photos may not be as final production, so please refer to the bike spec for clarification."



3



B

BOMBTRACK™

SCRIPT | ORANGE - BLACK | 700C

Sfr. 1299.00





S/50
M/54
L/57

W1790A
W1790B
W1790C

BIKE SIZE	S	M	L
HORIZONTAL TOPTUBE LENGTH (MM)	522	540	557
SEAT ANGLE (°)	75	75	75
HEADTUBE LENGTH (MM)	108	140	165
HEAD ANGLE (°)	72,25	72,5	72,5
SEAT TUBE LENGTH (C-T, MM)	500	540	570
BB DROP (MM)	47	47	47
CHAINSTAY LENGTH (MM)	387	387	387
FORK OFFSET (MM)	35	35	35
TRAIL (MM)	71	69	66
WHEELBASE LENGTH (MM)	953	971	988
STANDOVER (MM, CENTER TT - GROUND)	755	791	816
STACK (MM)	390	400	410
REACH (MM)	599	524	548
STEM (MM)	100	100	100
HANDLEBAR (MM, DROP CENTRE-CENTRE)	420	420	420
CRANKARM (MM)	165	165	165
SEAT POST DIAMETER (MM)	27,2	27,2	27,2

FRAME	7005 BUTTED ALLOY, TAPERED HEAD, TOP AND DOWN TUBE, STAINLESS STEEL DROPOUT PLATES
FORK	BT BIKES "SCRIPT" 35MM OFFSET, CARBON / ALLOY FORK, 1.1/8"-1.1/2" TAPERED
HANDLEBAR	BT BIKES "COMPACT" DROP BAR, BUTTED 6061-T6 ALLOY
GRIPS	BT BIKES "PRO" SHOCK-PROOF BAR TAPE
STEM	BT BIKES "ORIGIN" FORGED ALLOY STEM, -7°
HEADSET	FSA "NO.42/48" SEALED INTEGRATED, A-HEADSET, 1.1/8"-1.1/2"
LEVERS	TEKTRO "RL-721" TOP MOUNT HINGED LEVERS
SHIFTER	-
BRAKES	TEKTRO "R312" CALIPER BRAKES
CRANKSET	SRAM "OMNIUM" 7050 ALLOY CRANK
BB	SRAM "GXP"
PEDALS	NOT INCLUDED
CHAIN	KMC "510HX" 1/2"x1/8"
CHAINRING	SRAM "OMNIUM" 7075-T6 ALLOY, 48T
CASSETTE	17T THREADED, HEAT TREATED CRMO COG
DERAILLEUR	-
FRONT HUB	BT BIKES "DROME" SEALED FRONT ALLOY HUB, 9MM FEMALE BOLT AXLE, 32H
REAR HUB	BT BIKES "DROME" SEALED REAR ALLOY FLIP-FLOP TRACK HUB, 10MM REGULAR AXLE, 32H
FRONT RIM	BT BIKES "DRX30" DOUBLE WALL, 115, 32H
REAR RIM	BT BIKES "DRX30" DOUBLE WALL, 115, 32H
SEAT	BT BIKES "PRO" RAIL SEAT, VACUUM BONDED TOP COVER
SEAT POST	BT BIKES "SPDC-2" ALLOY SEATPOST
SEAT CLAMP	BT BIKES "ORIGIN" FORGED ALLOY SEATCLAMP
TIRES	KENDA "KRITERIUM" 700CX23C
FENDERS	-
CARRIER	-
WEIGHT	TBC

B BOMBTRACK™ ARISE | METALLIC BLACK | 700C

Sfr. 999.00



**BOMBTRACK™**

ARISE | METALLIC BLACK | 700C

S/51
M/54
L/58W1696A
W1696B
W1696C

BIKE SIZE	S	M	L
HORIZONTAL TOPTUBE LENGTH (MM)	524	550	576
SEAT ANGLE (°)	74	73.5	73.5
HEADTUBE LENGTH (MM)	120	143	180
HEAD ANGLE (°)	73	73.2	73.5
SEAT TUBE LENGTH (MM)	510	540	580
BB DROP (MM)	55	55	55
CHANSTAY LENGTH (MM)	420	420	420
FORK OFFSET (MM)	40	40	40
STEM (MM)	100	100	100
HANDLEBAR (MM)	420	440	440
CRANKARM (MM)	170	170	175
SEAT POST DIAMETER (MM)	27.2	27.2	27.2

FRAME	4130 FULL CRMO FRAME, WITH HEAT TREATED FRONT TRIANGLE, INC DERAILLEUR, FENDER & RACK MOUNTS
FORK	BT BIKES "ARISE" FORK, FULL 4130 CRMO, TAPERED DOUBLE BUTTED BLADES WITH FENDER & RACK MOUNTS
BARS	BT BIKES "CX" 6061-T6 BUTTED ALLOY, 9° FLAIED DROP BAR
GRIPS	BT BIKES "TEAM" PERFORATED BAR TAPE
STEM	BT BIKES FORGED ALLOY STEM,
HEADSET	FSA "ORBIT X" SEALED A-HEADSET, 1.1/8"
LEVER	TEKTRO "RL-340" BRAKE LEVERS
BRAKES	TEKTRO "RX5" MINI V-BRAKES
CRANKS	BT BIKES "TAF19" 6061 ALLOY, 170MM (S,M) 175MM (L)
BB	PRESS FIT 86 SEALED BB
PEDALS	NOT INCLUDED
CHAIN	KMC "510HX" 1/2" X 1/8" CHAIN
CHAINRING	BT BIKES ALLOY, CNC, 42T CHAINRING
DRIVER	17T COG
DERAILLEUR	-
SHIFTER	-
FRONT HUB	BT BIKES "ARISE" SEALED, 10MM FEMALE BOLT HUB, 32H
REAR HUB	BT BIKES "ARISE" SEALED ALLOY CASSETTE HUB, 10MM HOLLOW AXLE, 32H
FRONT RIM	BT BIKES "X2100" DOUBLE WALL, PIN JOINT RIM, 32H
REAR RIM	BT BIKES "X2100" DOUBLE WALL, PIN JOINT RIM, 32H
SEAT	FABRIC "SCOOP-SHALLOW" WITH CRMO RAILS
SEAT POST	BT BIKES "612" ALLOY SEATPOST
SEAT CLAMP	BT BIKES COLD FORGED ALLOY SEATCLAMP
TIRES	CONTINENTAL "CYCLOCROSS SPEED" 700C X 35C
MUDGUARDS	-
WEIGHT	9.8KG

B BOMBTRACK™

ARISE | METALLIC GOLD | 700C

Sfr. 999.00





S/51
M/54
L/58

W1791A
W1791B
W1791C

BIKE SIZE	S	M	L
HORIZONTAL TOPTUBE LENGTH (MM)	534	558	583
SEAT ANGLE (°)	73	73	73
HEADTUBE LENGTH (MM)	119	148	180
HEAD ANGLE (°)	70,5	71	72
SEAT TUBE LENGTH (C-T, MM)	510	540	580
BB DROP (MM)	65	65	65
CHAINSTAY LENGTH (MM)	425	425	425
FORK OFFSET (MM)	45	45	45
TRAIL (MM)	74,8	70,9	64,5
WHEELBASE LENGTH (MM)	1004	1025	1041
STANDOVER (MM, CENTER TT - GROUND)	774	802	839
STACK (MM)	370	385	400
REACH (MM)	536	566	600
STEM (MM)	100	110	110
HANDLEBAR (MM, DROP CENTRE-CENTRE)	420	440	440
CRANKARM (MM)	170	170	175
SEAT POST DIAMETER (MM)	27,2	27,2	27,2

FRAME	4130 CRMO FRAME, WITH HEAT TREATED FRONT TRIANGLE, REPLACEABLE HANGER, FENDER & RACK MOUNTS
FORK	BT BIKES "ARISE" FORK, 4130 CRMO, TAPERED DOUBLE BUTTED BLADES WITH FENDER & RACK MOUNTS
HANDLEBAR	BT BIKES "CX-10" 6061-T6 BUTTED ALLOY, 10° FLAIRED DROP BAR
GRIPS	BT BIKES "PRO" SHOCK-PROOF BAR TAPE
STEM	BT BIKES "ORIGIN" FORGED ALLOY STEM, -7°
HEADSET	FSA "ORBIT X" SEALED A-HEADSET, 1.1/8"
LEVERS	TEKTRO "RL-340" BRAKE LEVERS
SHIFTER	-
BRAKES	PROMAX "RENDER R" DISC BRAKES WITH 160MM ROTORS
CRANKSET	BT BIKES "TAF19" 6061 ALLOY
BB	BB68 THREADED, SEALED BOTTOM BRACKET
PEDALS	RIDE AWAY PEDALS
CHAIN	KMC "510HX" 1/2"X1/8"
CHAINRING	BT BIKES CNC ALLOY, 42T CHAINRING
CASSETTE	17T HEAT TREATED CRMO COG
DERAILLEUR	-
FRONT HUB	BT BIKES "TITLE-DISC" SEALED, 6-BOLT DISC HUB, QR AXLE, 32H
REAR HUB	BT BIKES "TITLE-DISC" SEALED, (11 SPEED) CASSETTE, 6-BOLT DISC HUB, QR AXLE, 32H
FRONT RIM	BT BIKES "XCD22" DOUBLE WALL, 119, 32H
REAR RIM	BT BIKES "XCD22" DOUBLE WALL, 119, 32H
SEAT	BT BIKES "ORIGIN" RAIL SEAT
SEAT POST	BT BIKES "612" ALLOY SEATPOST
SEAT CLAMP	BT BIKES "ORIGIN" FORGED ALLOY SEATCLAMP
TIRES	CONTINENTAL "CYCLOCROSS SPEED" 700CX35C
FENDERS	-
CARRIER	-
WEIGHT	TBC

B BOMBTRACK™

ARISE (GEARED) | METALLIC GREY | 700C

Sfr. 1199.00





S/51
M/54
L/58

W1792A
W1792B
W1792C

BIKE SIZE	S	M	L
HORIZONTAL TOPTUBE LENGTH (MM)	534	558	583
SEAT ANGLE (°)	73	73	73
HEADTUBE LENGTH (MM)	119	148	180
HEAD ANGLE (°)	70,5	71	72
SEAT TUBE LENGTH (C-T, MM)	510	540	580
BB DROP (MM)	65	65	65
CHAINSTAY LENGTH (MM)	425	425	425
FORK OFFSET (MM)	45	45	45
TRAIL (MM)	74,8	70,9	64,5
WHEELBASE LENGTH (MM)	1004	1025	1041
STANDOVER (MM, CENTER TT - GROUND)	774	802	839
STACK (MM)	370	385	400
REACH (MM)	536	566	600
STEM (MM)	100	110	110
HANDLEBAR (MM, DROP CENTRE-CENTRE)	420	440	440
CRANKARM (MM)	170	170	175
SEAT POST DIAMETER (MM)	27,2	27,2	27,2

FRAME	4130 CRMO FRAME, WITH HEAT TREATED FRONT TRIANGLE, REPLACEABLE HANGER, FENDER & RACK MOUNTS
FORK	BT BIKES "ARISE" FORK, 4130 CRMO, TAPERED DOUBLE BUTTED BLADES WITH FENDER & RACK MOUNTS
HANDLEBAR	BT BIKES "ORIGIN-FLAT" 6061-T6 BUTTED ALLOY BAR
GRIPS	BT BIKES LOCK-ON, 145MM GRIPS
STEM	BT BIKES "ORIGIN" FORGED ALLOY STEM, -7°
HEADSET	FSA "ORBIT X" SEALED A-HEADSET, 1.1/8"
LEVERS	TEKTRO "ML-520" BRAKE LEVERS
SHIFTER	SHIMANO "SL-S503" TRIGGER SHIFTER
BRAKES	PROMAX "RENDER" DISC BRAKES WITH 160MM ROTORS
CRANKSET	BT BIKES "TAF19" 6061 ALLOY
BB	BB68 THREADED, SEALED BOTTOM BRACKET
PEDALS	RIDE AWAY PEDALS
CHAIN	KMC "510HX" 1/2"x1/8"
CHAINRING	BT BIKES CNC ALLOY, 42T CHAINRING
CASSETTE	SHIMANO, 20T
DERAILLEUR	-
FRONT HUB	BT BIKES "TITLE-DISC" SEALED, 6-BOLT DISC HUB, QR AXLE, 32H
REAR HUB	SHIMANO, SG-C6000, NEXUS 8 SPEED, INTERNAL GEAR HUB
FRONT RIM	BT BIKES "XCD22" DOUBLE WALL, 119, 32H
REAR RIM	BT BIKES "XCD22" DOUBLE WALL, 119, 32H
SEAT	BT BIKES "ORIGIN" RAIL SEAT
SEAT POST	BT BIKES "612" ALLOY SEATPOST
SEAT CLAMP	BT BIKES "ORIGIN" FORGED ALLOY SEATCLAMP
TIRES	KENDA "TENDRIL" 700X35C
FENDERS	BT BIKES 50MM PLASTIC FENDERS
CARRIER	-
WEIGHT	TBC

B BOMBTRACK™

HOOK AL | MATT GREY | 700C

Sfr. 1699.00



B**BOMBTRACK™**

HOOK AL | MATT GREY | 700C



S/50 **W1793A**
M/53 **W1793B**
L/56 **W1793C**
XL/59 **W1793D**

BIKE SIZE	S	M	L	XL
HORIZONTAL TOPTUBE LENGTH (MM)	534	552	570	586
SEAT ANGLE (°)	73	73	73	73
HEADTUBE LENGTH (MM)	115	138	162	179
HEAD ANGLE (°)	71	71,5	72	72
SEAT TUBE LENGTH (C-T, MM)	500	530	560	590
BB DROP (MM)	65	65	65	65
CHAINSTAY LENGTH (MM)	425	425	425	425
FORK OFFSET (MM)	45	45	45	45
TRAIL (MM)	73	71	66	65
WHEELBASE LENGTH (MM)	1000	1014	1028	1044
STANDOVER (MM, CENTER TT - GROUND)	768	796	820	839
STACK (MM)	370	381	392	403
REACH (MM)	536	560	584	600
STEM (MM)	100	110	110	120
HANDLEBAR (MM, DROP CENTRE-CENTRE)	420	420	440	440
CRANKARM (MM)	172,5	172,5	175	175
SEAT POST DIAMETER (MM)	27,2	27,2	27,2	27,2

FRAME	7005 BUTTED ALLOY, TAPERED HEAD TUBE, FORMED TOP AND DOWN TUBES, REPLACEABLE HANGER
FORK	BT BIKES "CX-38" CARBON / ALLOY DISC FORK, 1.1/8"-1.1/2" TAPERED
HANDLEBAR	BT BIKES "CX-10" 6061-T6 BUTTED ALLOY, 10° FLAIRED DROP BAR
GRIPS	BT BIKES "PRO" SHOCK-PROOF BAR TAPE
STEM	BT BIKES "ORIGIN" FORGED ALLOY STEM, -7°
HEADSET	FSA "NO.42/48" SEALED INTEGRATED, A-HEADSET, 1.1/8"-1.1/2"
LEVERS	SRAM "RIVAL 1"
SHIFTER	SRAM "RIVAL 1" 1X11 (INTEG. WITH LEVER)
BRAKES	TRP "SPYRE" DISC BRAKES WITH 160MM ROTORS
CRANKSET	SRAM "S350-1"
BB	SRAM PRESS FIT BB 30
PEDALS	NOT INCLUDED
CHAIN	KMC "X11-1"
CHAINRING	SRAM "APEX 1" 38T
CASSETTE	SRAM 11SPD CASSETTE, 11-32
DERAILLEUR	SRAM "APEXL 1"
FRONT HUB	BT BIKES "TITLE-DISC" SEALED, 6-BOLT DISC HUB, QR AXLE, 24H
REAR HUB	BT BIKES "TITLE-DISC" SEALED, CASSETTE, 6-BOLT DISC HUB, QR AXLE, 24H
FRONT RIM	BT BIKES "XCD22" DOUBLE WALL, 119, 32H
REAR RIM	BT BIKES "XCD22" DOUBLE WALL, 119, 32H
SEAT	BT BIKES "PRO" RAIL SEAT, VACUUM BONDED TOP COVER
SEAT POST	BT BIKES '620' ALLOY MICRO-ADJUST SEATPOST
SEAT CLAMP	BT BIKES "ORIGIN" FORGED ALLOY SEATCLAMP
TIRES	CLEMENT "MXP" 700X33C
FENDERS	-
CARRIER	-
WEIGHT	TBC

B**BOMBTRACK™**

HOOK EXT | METALLIC GREY | 27.5"

Sfr . 2299 . 00



S/51
M/54
L/57

W1794A
W1794B
W1794C

BIKE SIZE	S	M	L
HORIZONTAL TOPTUBE LENGTH (MM)	541	558	575
SEAT ANGLE (°)	72,5	72,5	72,5
HEADTUBE LENGTH (MM)	110	131	149
HEAD ANGLE (°)	70,25	71	72
SEAT TUBE LENGTH (C-T, MM)	510	540	570
BB DROP (MM)	70	70	70
CHAINSTAY LENGTH (MM)	425	425	425
FORK OFFSET (MM)	45	45	45
TRAIL (MM)	75	70	64
WHEELBASE LENGTH (MM)	1007	1024	1024
STANDOVER (MM, CENTER TT - GROUND)	765	790	815
STACK (MM)	370	380	390
REACH (MM)	544	566	587
STEM (MM)	100	110	110
HANDLEBAR (MM, DROP CENTRE-CENTRE)	420	420	440
CRANKARM (MM)	172,5	172,5	175
SEAT POST DIAMETER (MM)	27,2	27,2	27,2

FRAME	COLUMBUS "CROMOR" TUBING, INVEST CASTED TA DROPOUT, REPL. HANGER, RACK & FENDER MOUNTS
FORK	BT BIKES "CX-PLUS" CARBON / ALLOY TA DISC FORK, 1.1/8"-1.1/2" TAPERED STEERER TUBE
HANDLEBAR	BT BIKES "CX-10" 6061-T6 BUTTED ALLOY, 10° FLAIRED DROP BAR
GRIPS	BT BIKES "PRO" SHOCK-PROOF BAR TAPE
STEM	BT BIKES "ORIGIN" FORGED ALLOY STEM, -7°
HEADSET	FSA "ORBIT ITA" SEALED A-HEADSET, TAPERED 1.1/8"-1.1/2"
LEVERS	SRAM "RIVAL 1" HYDRAULIC
SHIFTER	SRAM "RIVAL 1" 1X11 (INTEG. WITH LEVER)
BRAKES	SRAM "RIVAL" FLAT MOUNT HYDRAULIC WITH 160MM F / 140MM R ROTORS
CRANKSET	SRAM "RIVAL 1"
BB	FSA 386EVO
PEDALS	NOT INCLUDED
CHAIN	KMC "X11-1"
CHAINRING	SRAM "X-SYNC" ALLOY, 44T
CASSETTE	SRAM 11SPD CASSETTE, 11-36
DERAILLEUR	SRAM "RIVAL 1"
FRONT HUB	BT BIKES "ORIGIN" SEALED, CL DISC HUB, 15X100 MM THRU-AXLE
REAR HUB	BT BIKES "ORIGIN" SEALED, CASSETTE CL DISC HUB, 12X142 MM THRU-AXLE
FRONT RIM	WTB "STS" DOUBLE WALL SLEEVED, TLC, I19, 32H
REAR RIM	WTB "STS" DOUBLE WALL SLEEVED, TLC, I19, 32H
SEAT	SELLE SAN MARCO "SQUADRA-STARTUP"
SEAT POST	BT BIKES '612' ALLOY MICRO-ADJUST SEATPOST
SEAT CLAMP	BT BIKES "ORIGIN" FORGED ALLOY SEATCLAMP
TIRES	WTB "NANO" 27.5"X2.1"
FENDERS	-
CARRIER	-
WEIGHT	TBC



BOMBTRACK™

BEYOND | MATT METALLIC GREEN | 700C

Sfr.1799.00





S/47
M/49
L/52

W1795A
W1795B
W1795C

BIKE SIZE	S	M	L
HORIZONTAL TOPTUBE LENGTH (MM)	555	575	600
SEAT ANGLE (°)	74	73,5	73
HEADTUBE LENGTH (MM)	160	185	210
HEAD ANGLE (°)	71	72	72
SEAT TUBE LENGTH (C-T, MM)	475	495	525
BB DROP (MM)	70	70	70
CHAINSTAY LENGTH (MM)	455	455	455
FORK OFFSET (MM)	45	45	45
TRAIL (MM)	76	70	70
WHEELBASE LENGTH (MM)	1063	1067	1086
STANDOVER (MM, CENTER TT - GROUND)	791	813	839
STACK (MM)	379	385	396
REACH (MM)	613	640	664
STEM (MM)	90	90	100
HANDLEBAR (MM, DROP CENTRE-CENTRE)	440	440	460
CRANKARM (MM)	170	175	175
SEAT POST DIAMETER (MM)	27,2	27,2	27,2

FRAME	COLUMBUS "CROMOR" TUBING, WITH X3 CAGE, RACK & FENDER MOUNTS, REPL HANGER
FORK	BT BIKES "BEYOND" 4130 DOUBLE BUTTED TAPERED CRMO WITH FENDER, RACK AND BOTTLE MOUNTS
HANDLEBAR	BT BIKES "BEYOND" 6061-T6 BUTTED ALLOY, 22° FLAIRED TRAVEL BAR
GRIPS	BT BIKES "TEAM" PERFORATED BAR TAPE (FAUX LEATHER)
STEM	BT BIKES FORGED ALLOY STEM, +17°
HEADSET	FSA "N021/12/44" SEALED A-HEADSET, 1.1/8"-1.1/2"
LEVERS	SRAM "APEX"
SHIFTER	SRAM "APEX" 2X10 (INTEG. WITH LEVER)
BRAKES	TRP "SPYRE" DISC BRAKES WITH 160MM ROTORS
CRANKSET	SRAM X5
BB	SRAM GXP73
PEDALS	NOT INCLUDED
CHAIN	KMC "X10EL"
CHAINRING	SRAM 28/42T
CASSETTE	SRAM 10 SPEED CASSETTE, 11-36T
DERAILLEUR	SRAM "GX"/7X" REAR AND "X5" FRONT
FRONT HUB	BT BIKES "TITLE-DISC" SEALED, 6-BOLT DISC HUB, 15X100MM THRU-AXLE
REAR HUB	BT BIKES "TITLE-DISC" SEALED, CASSETTE, 6-BOLT DISC HUB, QR AXLE
FRONT RIM	WTB "STS" DOUBLE WALL SLEEVED, TLC, I19, 32H
REAR RIM	WTB "STS" DOUBLE WALL SLEEVED, TLC, I19, 32H
SEAT	BT BIKES "ORIGIN" RAIL SEAT
SEAT POST	BT BIKES "620" ALLOY SEATPOST
SEAT CLAMP	BT BIKES "ORIGIN" FORGED ALLOY SEATCLAMP
TIRES	WTB "NANO" 29"X2.1", FOLDING TIRE
FENDERS	-
CARRIER	-
WEIGHT	TBC

B BOMBTRACK™ AUDAX | METALLIC WHITE | 700C

Sfr.1899.00



B BOMBTRACK™ AUDAX | METALLIC WHITE | 700C



S/51
M/53
L/55

W1690A
W1690B
W1690C

BIKE SIZE	S	M	L
HORIZONTAL TOPTUBE LENGTH (MM)	545	560	575
SEAT ANGLE (°)	73	73	72.5
HEADTUBE LENGTH (MM)	120	135	155
HEAD ANGLE (°)	71	71	71.5
SEAT TUBE LENGTH (MM)	510	530	550
BB DROP (MM)	72	72	72
CHANSTAY LENGTH (MM)	430	430	430
FORK OFFSET (MM)	45	45	45
STEM (MM)	100	110	110
HANDLEBAR (MM)	440	440	440
CRANKARM (MM)	172.5	172.5	175
SEAT POST DIAMETER (MM)	27.2	27.2	27.2

FRAME	4130 FULL CRMO FRAME, WITH HEAT TREATED FRONT TRIANGLE, INC FENDER AND RACK MOUNTS
FORK	BT BIKES "AUDAX" FORK, CARBON / ALLOY, WITH FENDER MOUNTS
BARS	BT BIKES, 6061-T6 DOUBLE BUTTED ALLOY, DROP BAR
GRIPS	BT BIKES "PRO" BAR TAPE WITH VEX GEL
STEM	BT BIKES ALLOY STEM
HEADSET	FSA "ORBIT X" SEALED A-HEADSET, 1.1/8"
LEVER	SHIMANO "105"
BRAKES	TEKTRO "R359" ALLOY, LONG ARM CALLIPER BRAKES
CRANKS	SHIMANO "105"
BB	SHIMANO, 1.37"X 68MM, EXTERNAL SEALED BB
PEDALS	NOT INCLUDED
CHAIN	KMC "X11L" CHAIN
CHAINRING	SHIMANO "105" COMPACT 50/34T
DRIVER	SHIMANO "105" 11 SPEED, 11-28T
DERAILLEUR	SHIMANO "105" FRONT AND REAR
SHIFTER	SHIMANO "105" INTEG. WITH LEVER
FRONT HUB	DT SWISS "R24 SPLINE" SEALED BEARING, 9MM QR SQUERS
REAR HUB	DT SWISS "R24 SPLINE" SEALED BEARING, 9MM QR SQUERS
FRONT RIM	DT SWISS "R24 SPLINE" DOUBLE WALL PINNED, 22MM WIDE, TUBLESS COMPAT. 24H
REAR RIM	DT SWISS "R24 SPLINE" DOUBLE WALL PINNED, 22MM WIDE, TUBLESS COMPAT. 24H
SEAT	FABRIC "SCOOP-SHALLOW" WITH CRMO RAILS
SEAT POST	BT BIKES "620" ALLOY SEATPOST
SEAT CLAMP	BT BIKES ALLOY SEATCLAMP
TIRES	CONTINENTAL "GRAND SPORT RACE" 700C X 28C
MUDGUARDS	BT BIKES 35MM PLASTIC GUARDS
WEIGHT	9.8KG

B

BOMBTRACK™

OXBRIDGE SS | METALLIC DARK GREEN | 700C

Sfr. 899.00





S/51
M/54
L/57

W1796A
W1796B
W1796C

BIKE SIZE	S	M	L
HORIZONTAL TOPTUBE LENGTH (MM)	528	546	656
SEAT ANGLE (°)	73	73	73
HEADTUBE LENGTH (MM)	100	126	153
HEAD ANGLE (°)	69,5	71	71,5
SEAT TUBE LENGTH (C-T, MM)	510	540	570
BB DROP (MM)	65	65	65
CHAINSTAY LENGTH (MM)	416	416	416
FORK OFFSET (MM)	50	50	50
TRAIL (MM)	73	64	60
WHEELBASE LENGTH (MM)	1003	1008	1024
STANDOVER (MM, CENTER TT - GROUND)	757	787	815
STACK (MM)	372	381	392
REACH (MM)	511	541	568
STEM (MM)	80	80	100
HANDLEBAR (MM, DROP CENTRE-CENTRE)	560	560	560
CRANKARM (MM)	165	165	170
SEAT POST DIAMETER (MM)	27,2	27,2	27,2

FRAME	4130 CRMO HEAD, DOWN AND SEAT TUBE, CRMO DROPOUTS WITH FENDER MOUNTS
FORK	BT BIKES "OXBRIDGE" FULL 4130 CRMO FORK, WITH RACK AND FENDER MOUNTS
HANDLEBAR	BT BIKES "OXBRIDGE" 6061-T6 ALLOY BAR
GRIPS	VELO CLAMP ON GRIP WITH LEATHER BAR TAPE
STEM	BT BIKES GOOSE NECK FORGED ALLOY STEM
HEADSET	FSA "DURON X" SEALED BEARING, 1" THREADED
LEVERS	PROMAX "249A" ALLOY BRAKE LEVERS
SHIFTER	-
BRAKES	TEKTRO "R359" ALLOY CALIPER BRAKES
CRANKSET	BT BIKES "AF22" 6061 ALLOY
BB	BT BIKES 1.37"X68MM SEALED BB
PEDALS	BT BIKES CAGE ALLOY PEDAL
CHAIN	KMC "510HX" 1/2"X1/8" CHAIN
CHAINRING	BT BIKES ALLOY, CNC, 44T CHAINRING
CASSETTE	16T FREEWHEEL
DERAILLEUR	-
FRONT HUB	BT BIKES "DROME" SEALED FRONT HUB, 9MM FEMALE BOLT AXLE
REAR HUB	BT BIKES "DROME" SEALED FREEWHEEL HUB, 10MM FEMALE BOLT AXLE
FRONT RIM	BT BIKES "DRX" DOUBLE WALL, 116, 28H
REAR RIM	BT BIKES "DRX" DOUBLE WALL, 116, 28H
SEAT	BT BIKES "TEAM" SLIM PADDED RAIL SEAT
SEAT POST	BT BIKES "375" ALLOY MICRO-ADJUST SEATPOST
SEAT CLAMP	INTEGRATED SEAT CLAMP
TIRES	KENDA 700X28C
FENDERS	BT BIKES ALLOY FENDERS
CARRIER	-
WEIGHT	10.2KG (PREDICTED)

B

BOMBTRACK™

OXBRIDGE (GEARED) | METALLIC DARK BROWN | 700C

Sfr. 999.00





S/51
M/54
L/57

W1797A
W1797B
W1797C

BIKE SIZE	S	M	L
HORIZONTAL TOPTUBE LENGTH (MM)	528	546	656
SEAT ANGLE (°)	73	73	73
HEADTUBE LENGTH (MM)	100	126	153
HEAD ANGLE (°)	69,5	71	71,5
SEAT TUBE LENGTH (C-T, MM)	510	540	570
BB DROP (MM)	65	65	65
CHAINSTAY LENGTH (MM)	416	416	416
FORK OFFSET (MM)	50	50	50
TRAIL (MM)	73	64	60
WHEELBASE LENGTH (MM)	1003	1008	1024
STANDOVER (MM, CENTER TT - GROUND)	757	787	815
STACK (MM)	372	381	392
REACH (MM)	511	541	568
STEM (MM)	80	80	100
HANDLEBAR (MM, DROP CENTRE-CENTRE)	560	560	560
CRANKARM (MM)	165	165	170
SEAT POST DIAMETER (MM)	27,2	27,2	27,2

FRAME	4130 CRMO HEAD, DOWN AND SEAT TUBE, CRMO DROPOUTS WITH RACK & FENDER MOUNTS
FORK	BT BIKES "OXBRIDGE" FULL 4130 CRMO FORK, WITH RACK AND FENDER MOUNTS
HANDLEBAR	BT BIKES "OXBRIDGE" 6061-T6 ALLOY DROP BAR
GRIPS	BT BIKES "CLASSIC" BAR TAPE (FAUX LEATHER)
STEM	BT BIKES GOOSE NECK FORGED ALLOY STEM
HEADSET	FSA "DURON X" SEALED BEARING, 1" THREADED
LEVERS	TEKTRO "RF340" LEVERS
SHIFTER	DIA COMPE DOWNTUBE SHIFTERS
BRAKES	TEKTRO "R359" ALLOY CALIPER BRAKES
CRANKSET	BT BIKES "AF22" 6061 ALLOY
BB	BT BIKES 1.37"X68MM SEALED BB
PEDALS	BT BIKES CAGE ALLOY PEDAL
CHAIN	KMC "X10" CHAIN
CHAINRING	BT BIKES CNC, 48T CHAINRING AND COVER
CASSETTE	SHIMANO "TIAGRA" 10-SPEED, 12-28
DERAILLEUR	SHIMANO "TIAGRA" 10-SPEED
FRONT HUB	BT BIKES "DROME" SEALED FRONT HUB, 9MM FEMALE BOLT AXLE
REAR HUB	BT BIKES "DROME" SEALED CASSETTE HUB, 10MM FEMALE BOLT AXLE
FRONT RIM	BT BIKES "DRX" DOUBLE WALL, 116, 28H
REAR RIM	BT BIKES "DRX" DOUBLE WALL, 116, 28H
SEAT	BT BIKES "HARRIS" SLIM PADDED RAIL SEAT
SEAT POST	BT BIKES "375" ALLOY MICRO-ADJUST SEATPOST
SEAT CLAMP	INTEGRATED SEAT CLAMP
TIRES	KENDA 700CX28C
FENDERS	BT BIKES ALLOY FENDERS
CARRIER	
WEIGHT	10.8KG (PREDICTED)

find a dealer for:

RADIO



find a dealer for:

BOMBTRACK
BICYCLE COMPANY

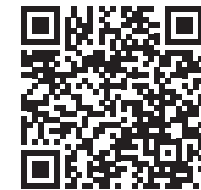

find a dealer for:

WETHEPEOPLE



ihr fachhändler / votre marchand